

NAVWEPS 01-85FGG-501

# Flight Handbook

*NAVY MODEL*

F11F-1

AIRCRAFT



THIS PUBLICATION SUPERSEDES NAVAER 01-85FGG-501 DATED 15 JULY 1957.  
REVISED 15 MARCH 1959 AND NAVAER 01-85FGG-501A DATED 15 OCTOBER 1957.  
REVISED 15 MARCH 1959

PUBLISHED BY DIRECTION OF  
THE CHIEF OF THE BUREAU OF NAVAL WEAPONS

*1 December 1960*

Reproduction for non-military use of the information or illustrations contained in this publication is not permitted without specific approval of the issuing service (BUWEPS or AMC). The policy for use of Classified Publications is established for the Air Force in AFR 205-1 and for the Navy in Navy Regulations, Article 1509.

**LIST OF REVISED PAGES ISSUED**

**INSERT LATEST REVISED PAGES. DESTROY SUPERSEDED PAGES**

NOTE: The portion of the text affected by the current revision is indicated by a vertical line in the outer margins of the page.

\*The asterisk indicates pages revised, added or deleted by the current revision.

BUWEPS

**ADDITIONAL COPIES OF THIS PUBLICATION MAY BE OBTAINED AS FOLLOWS:**

USAF ACTIVITIES.—In accordance with Technical Order No. 00-5-2.

NAVY ACTIVITIES.—Submit request to nearest supply point listed below, using form NAVWEPS 140: NASD, Philadelphia, Pa.; NAS, Alameda, Calif.; NAS, Jacksonville, Fla.; NAS, Norfolk, Va.; NAS, San Diego, Calif.; NAS, Seattle, Wash.; ASD, NSC, Guam.

For listing of available material and details of distribution see Naval Weapons Publications Index NAVWEPS 00-500.

**TABLE OF CONTENTS**

<i>Section</i>		<i>Page</i>
I	Description .....	1
II	Normal Procedures .....	57
III	Emergency Procedures .....	73
IV	Description and Operation of Auxiliary Equipment .....	91
V	Operating Limitations .....	115
VI	Flight Characteristics .....	123
VII	Systems Operation .....	133
VIII	Crew Duties (Not Applicable) .....	137
IX	All Weather Operation .....	139
Appendix I	Operating Data .....	143

**This page intentionally left blank.**

## IMPORTANT

*To gain the maximum benefits from this handbook it is imperative that you read this page carefully.*

## FOREWORD

The function of this flight handbook is to acquaint the pilot with the airplane, furnishing information necessary for normal and emergency flight. It is most important that the pilot keep abreast of all pertinent Interim Revisions which may have been issued since the publication of this handbook, but which may not yet have been incorporated in the form of handbook revisions.

The pilot's flying experience is recognized; these instructions are not intended to teach the basic principals of flight but are designed to provide the pilot with a general knowledge of the airplane.

This handbook is divided into sections as follows:

**SECTION I, DESCRIPTION.** This section describes the airplane and its systems and controls which contribute to the physical act of flying the airplane. Also included is emergency equipment which is not part of an emergency system.

**SECTION II, NORMAL PROCEDURES.** Included in this section are the procedures to be followed on a non-tactical flight under normal conditions, from the time the pilot approaches the airplane until the flight is completed and the airplane is left parked on the ramp.

**SECTION III, EMERGENCY PROCEDURES.** The procedures to be followed in meeting any emergency that the pilot could reasonably expect to encounter, except those in connection with auxiliary equipment, are described in this section.

**SECTION IV, DESCRIPTION AND OPERATION OF AUXILIARY EQUIPMENT.** This section includes description, normal operation and emergency operation of all equipment not directly contributing to flight but which enables the airplane to perform specialized functions.

**SECTION V, OPERATING LIMITATIONS.** All important limitations which must be observed during normal operation of the airplane are covered in this section.

**SECTION VI, FLIGHT CHARACTERISTICS.** This section describes the unique characteristics of this airplane in flight.

**SECTION VII, SYSTEMS OPERATION.** Operation of the various airplane systems under varying conditions is discussed in this section, with emphasis given to any special problems which must be considered.

**SECTION VIII, CREW DUTIES.** Not applicable.

**SECTION IX, ALL WEATHER OPERATION.** This section contains procedures to be followed under extreme climatic conditions. No repetition is made of procedures given in other sections.

**APPENDIX I, OPERATING DATA.** This section contains all operating data charts and tables necessary for preflight and inflight mission planning and explanatory text on the use of the data presented.

# F11F-1 TIGER

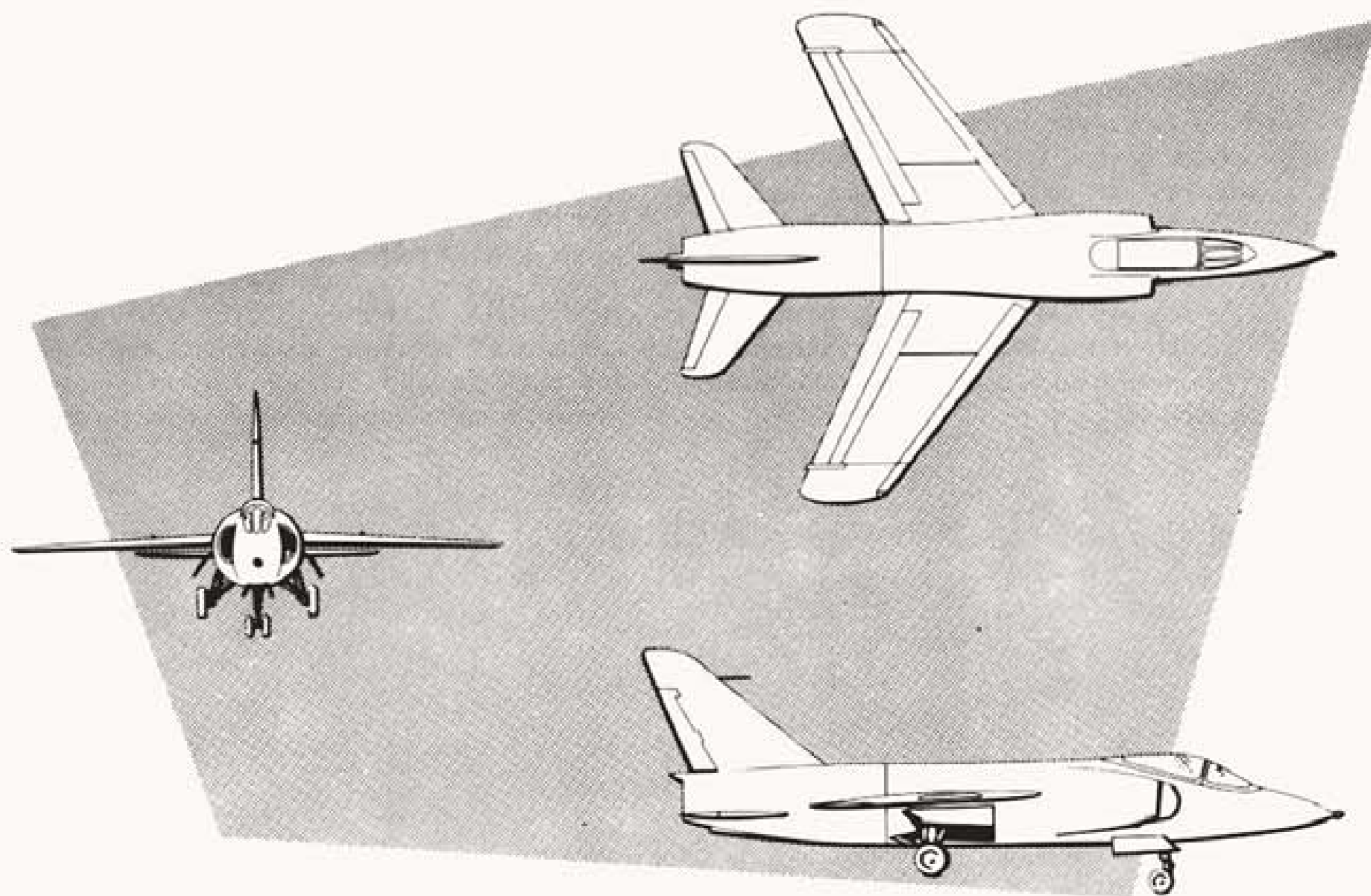
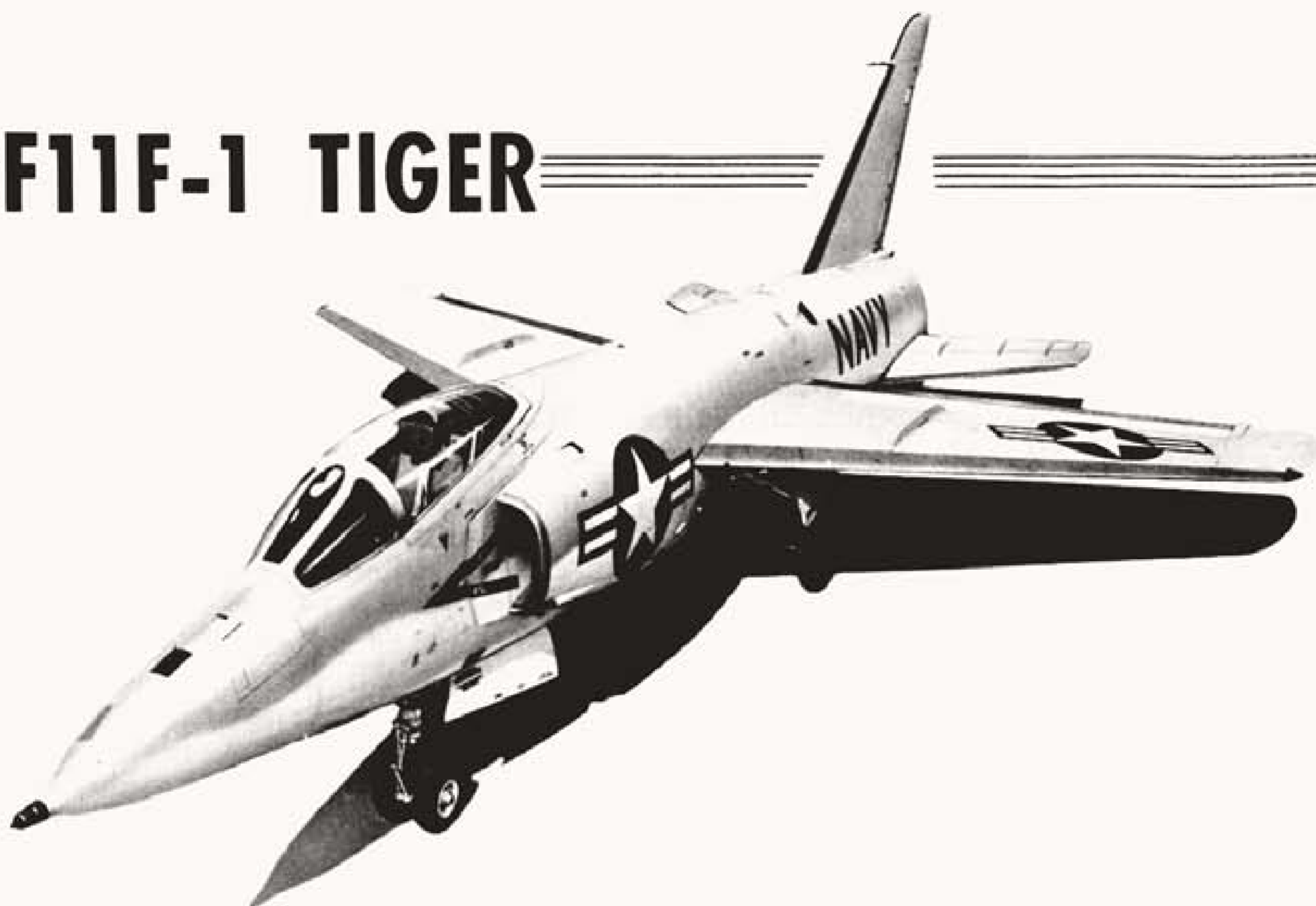

Figure 1-1. F11F-1 Airplane

**Section I**



**DESCRIPTION**

**AIRPLANE.**

The F11F-1 airplane is a swept wing, single place, turbo-jet powered, carrier based, high performance day and night visual fighter designed and manufactured by the Grumman Aircraft Engineering Corporation. It is armed with four 20mm MK 12 guns and is equipped to carry missiles. Longitudinal control is achieved by an all movable stabilizer located below the tailpipe centerline. Vented flaperons are installed for lateral control. The rudder, flaperons and all movable stabilizer are actuated by a dual hydraulic power system designed for maximum reliability. Hydraulic powered leading edge slats and large span flaps are incorporated to improve the low speed lift characteristics of the wing.

The principal dimensions of the F11F-1 airplane are:

Span .....	31 ft 7-1/2 in.
Span (wing tips folded) .....	27 ft 4 in.
Length <sup>1</sup> .....	44 ft 1-1/2 in.
Length <sup>2</sup> .....	47 ft 9 in.
Height .....	13 ft 2-3/4 in.

**ENGINE.**

The J65-W-18 engine is of the axial flow type and incorporates 13 compressor stages and two turbine stages rotating clockwise as viewed from the rear. The engine is equipped with an afterburner and a two position convergent nozzle. An automatic control

system for positioning the nozzle in afterburner is provided. The engine is equipped with a four element fuel pump, a self-contained lubricating system and a speed-density type fuel control system.

The rated thrust of the engine is as follows:

Maximum Thrust (afterburner on) .....	10500 lb
Military Thrust (afterburner off) .....	7450 lb
Normal Thrust (continuous) .....	6470 lb

**ENGINE FUEL CONTROL SYSTEM.**

This system (figure 1-3) consists of a fuel pump, fuel control unit, six flow dividers, a fuel primer solenoid and two primers. The fuel pump has a high pressure section consisting of three parallel gear elements in series with a centrifugal boost pump. Normally, one element supplies the engine and the other two supply the afterburner. If the engine element fails, the secondary afterburner element will assume its function and will supply enough fuel to operate the engine under all conditions; while the remaining afterburner element will permit partial operation of the afterburner. Fuel flows from the main tank submerged electric boost pump through the engine fuel inlet, the low pressure boost portion of the engine pump, then through the high pressure portion of the engine pump to the engine fuel control unit. Failure of the main element only of the high pressure gear pump will cause the high pressure

<sup>1</sup>Airplanes BuNo. 138610a through 138645b.

<sup>2</sup>Airplanes BuNo. 141728c and subsequent.

# General Arrangement

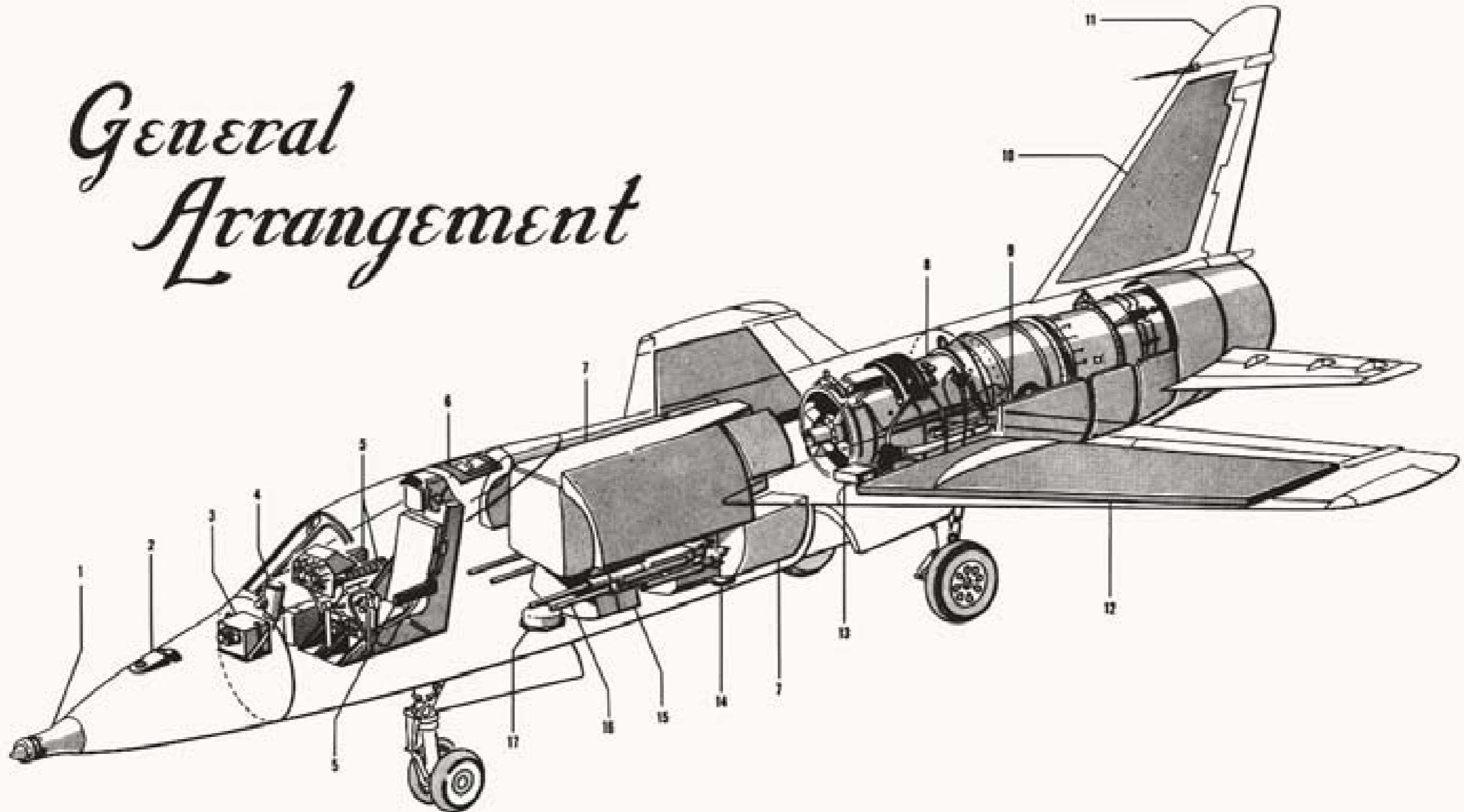

1. In-flight Refueling Probe
2. Radar Antenna
3. Battery
4. Gun Sight Unit
5. Circuit Breaker Panels (3)
6. VHF Navigation System Antenna

7. Main Fuel Tank
8. Engine
9. Aft Fuel Tank
10. Fin Fuel Tank
11. UHF Communication System Antenna
12. Wing Fuel Tank (2)

13. External Power Receptacle
14. IFF Antenna
15. Ammunition Boxes
16. 20MM Guns
17. UHF Homing Adapter Antenna

Figure 1-2. General Arrangement



# ENGINE FUEL CONTROL SYSTEM SCHEMATIC

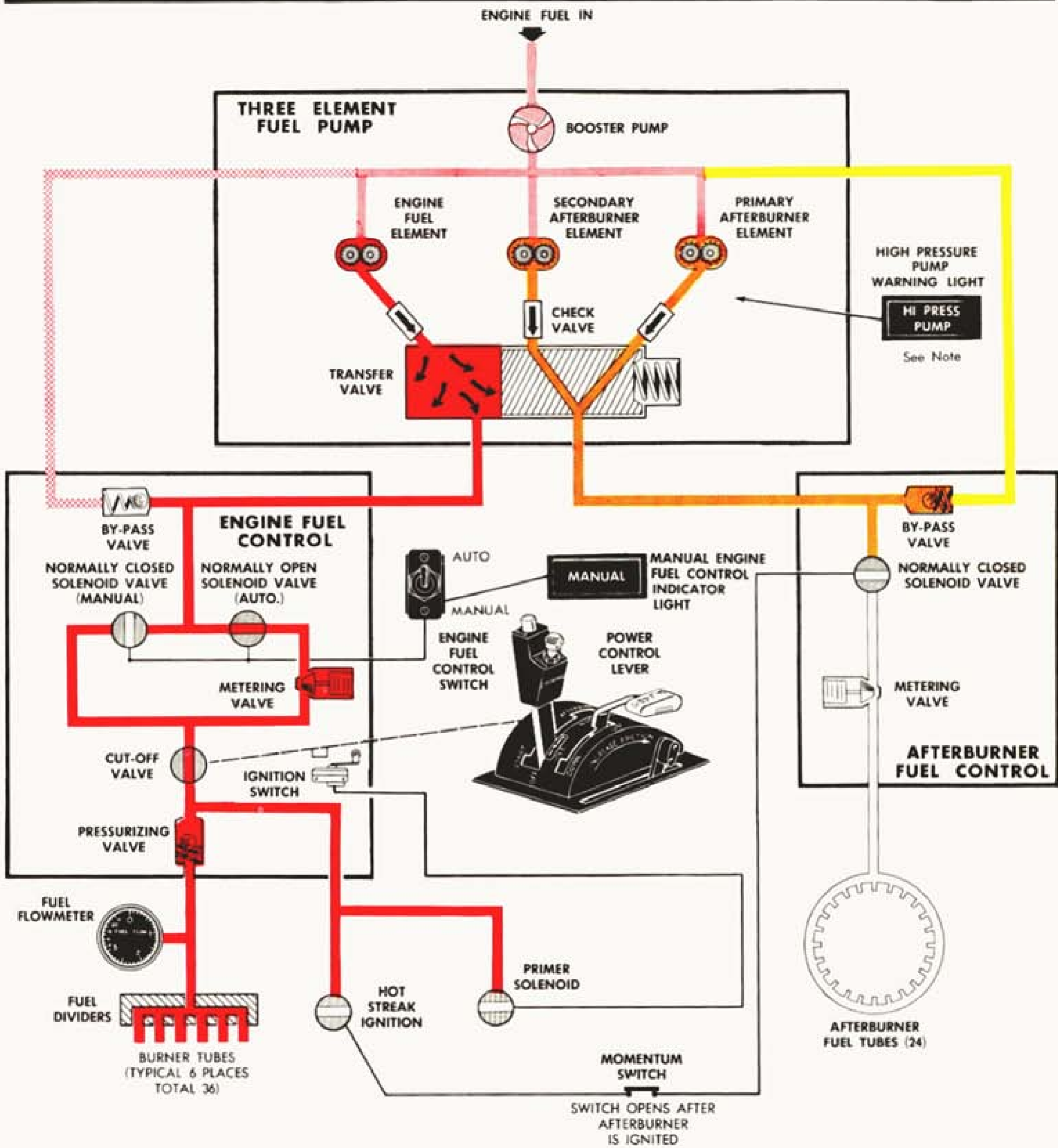

*Note*

THE HIGH PRESSURE PUMP WARNING LIGHT GLOWS WHEN THE MAIN ELEMENT OF THE THREE ELEMENT FUEL PUMP FAILS.

*Code*

- LOW PRESSURE FUEL
- HIGH PRESSURE FUEL
- MAIN BY-PASS FUEL
- AFTERBURNER FUEL
- AFTERBURNER BY-PASS FUEL

Figure 1-3. Engine Fuel Control System—Schematic

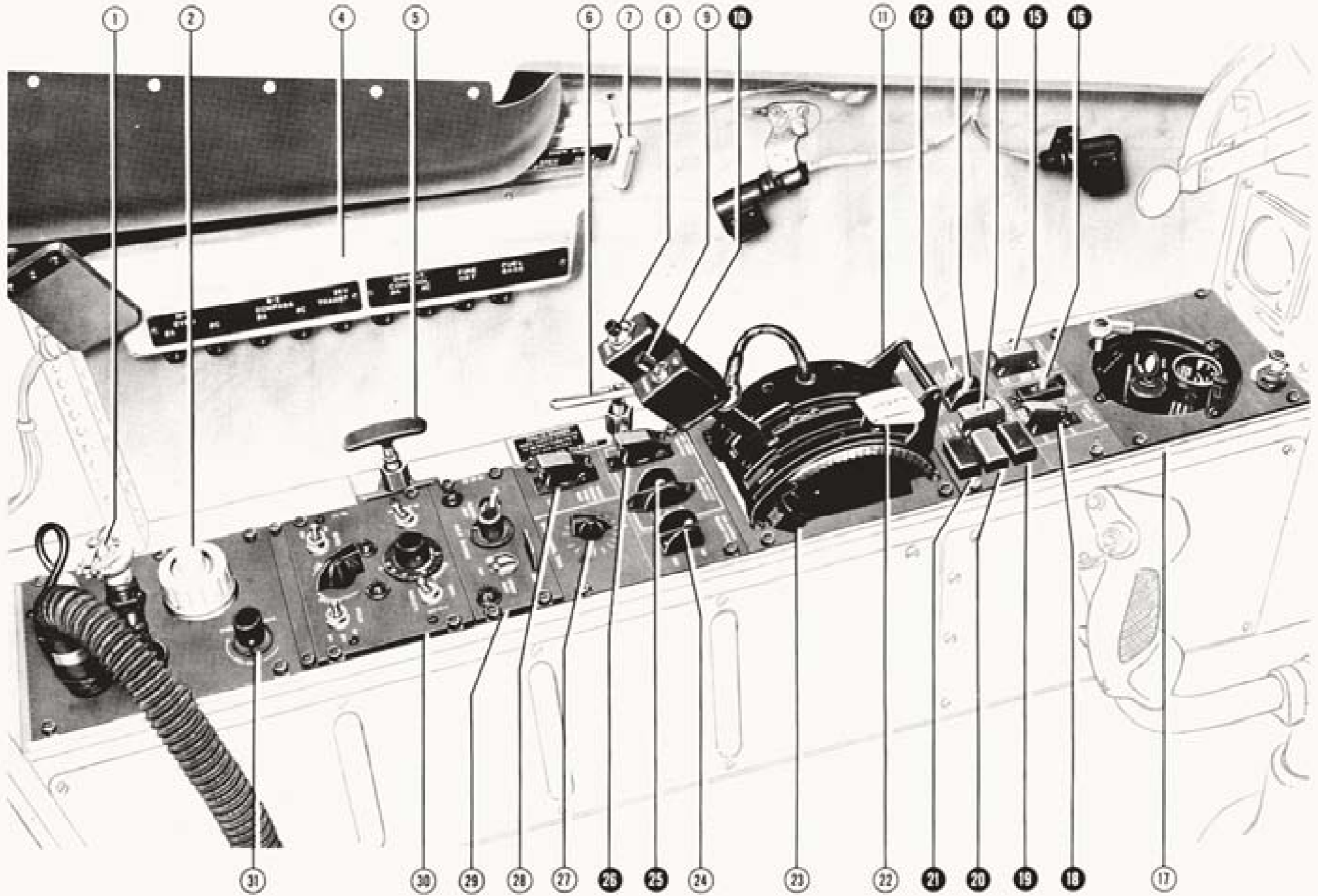

Figure 1-4. Cockpit, Left Side—Airplanes BuNo. 138610a Through 138645b

KEY TO FIGURE 1-4

- |   |   |
|---|---|
| 1. Anti-Blackout Suit Tube Receptacle         | 17. Oxygen Control Panel                  |
| 2. Anti-Blackout Valve Control Knob           | 18. Wing Fuel Dump Switch                 |
| 3. DELETED                                    | 19. High Pressure Fuel Pump Warning Light |
| 4. Circuit Breaker Panel                      | 20. Manual Fuel Control Indicator Light   |
| 5. Wheel Brakes Emergency Control Handle      | 21. Low Pressure Fuel Pump Warning Light  |
| 6. Emergency Hydraulic Turbine Control Handle | 22. Flaps Control Handle                  |
| 7. Cockpit Air Diffuser Control Handle        | 23. Power Control Lever Friction Control  |
| 8. Microphone Switch                          | 24. Yaw Damper and Rudder Trim Switch     |
| 9. Speed Brakes Switch                        | 25. Afterburner Nozzle Override Switch    |
| 10. Power Control Lever                       | 26. Airstart Ignition Switch              |
| 11. Catapult Grip                             | 27. Directional Trim Control Knob         |
| 12. Boost Pump Cut-Off Switch                 | 28. Speed Brakes Override Switch          |
| 13. Engine Fuel Control Switch                | 29. Radar Control Panel                   |
| 14. Fuel Tank Emergency Selector Switch       | 30. MK 35 Mod 2 Fire Control Panel        |
| 15. Wing Fuel Transfer Switch                 | 31. Radar Tone Volume Control Knob        |
| 16. Fuel Tank Pressure Switch                 |   |

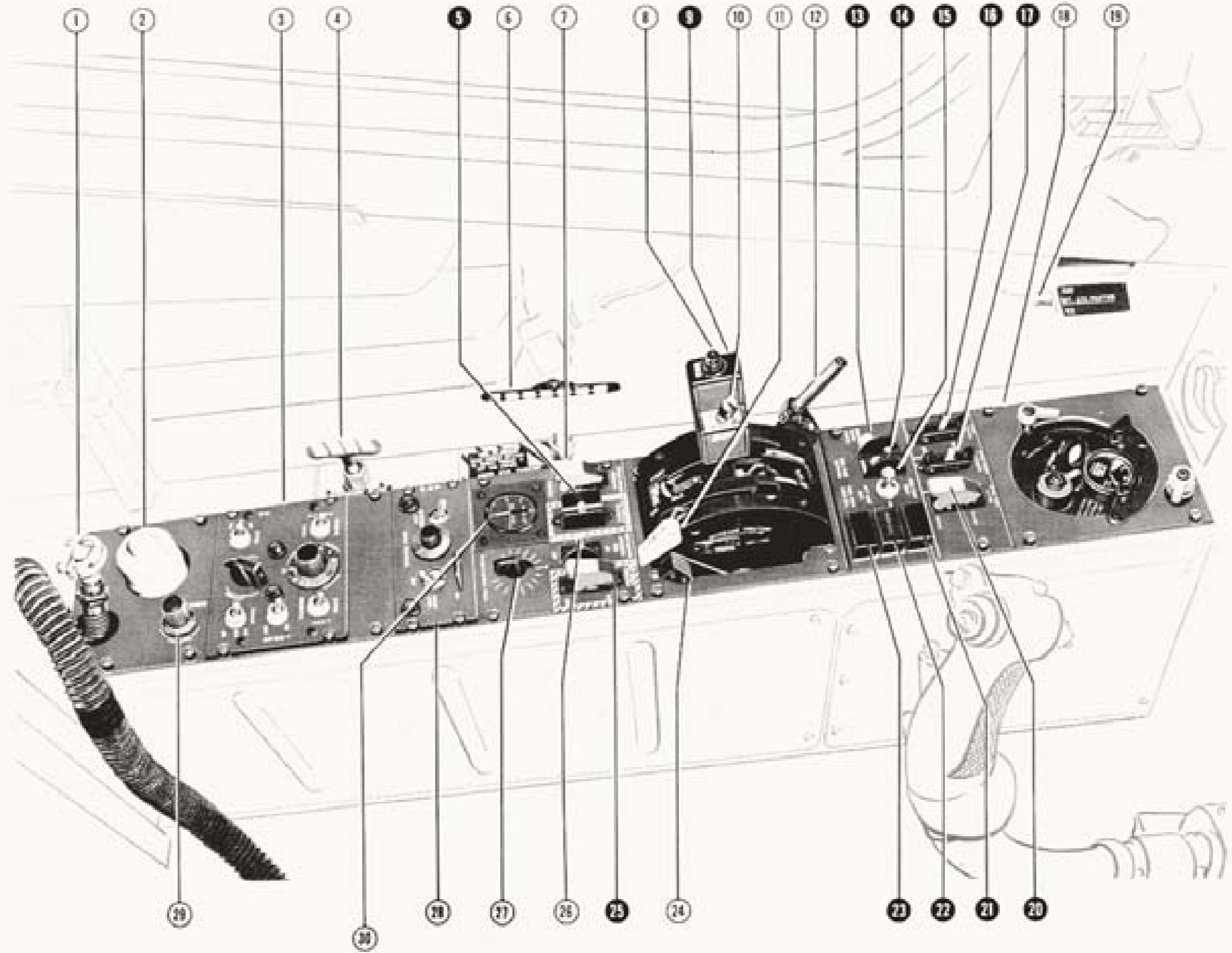

Figure 1-4A. Cockpit, Left Side—Airplanes BuNo. 141728c and Subsequent

KEY TO FIGURE 1-4A

1. Anti-Blackout Suit Tube Receptacle
2. Anti-Blackout Valve Control Knob
3. MK 44 Mod 0 Control Box
4. Wheel Brakes Emergency Control Handle
5. Afterburner Nozzle Override Switch
6. Emergency Hydraulic Turbine Control Handle
7. Speed Brakes Override Switch
8. Microphone Switch
9. Power Control Lever
10. Speed Brakes Switch
11. Flaps Control Handle
12. Catapult Grip
13. Boost Pump Cut-Off Switch
14. Engine Fuel Control Switch
15. Fuel Tank Emergency Selector Switch
16. Wing Fuel Transfer Switch
17. Fuel Tank Pressure Switch
18. Oxygen Control Panel
19. Exterior Lights Auxiliary Master Switch
20. Wing Fuel Dump Switch
21. High Pressure Fuel Pump Warning Light
22. Manual Fuel Control Indicator Light
23. Low Pressure Fuel Pump Warning Light
24. Power Control Lever Friction Control
25. Airstart Ignition Switch
26. Yaw Damper and Rudder Trim Switch
27. Directional Trim Control Knob
28. Radar Control Panel
29. Radar Tone Volume Control Knob
30. Cockpit Pressure Altimeter

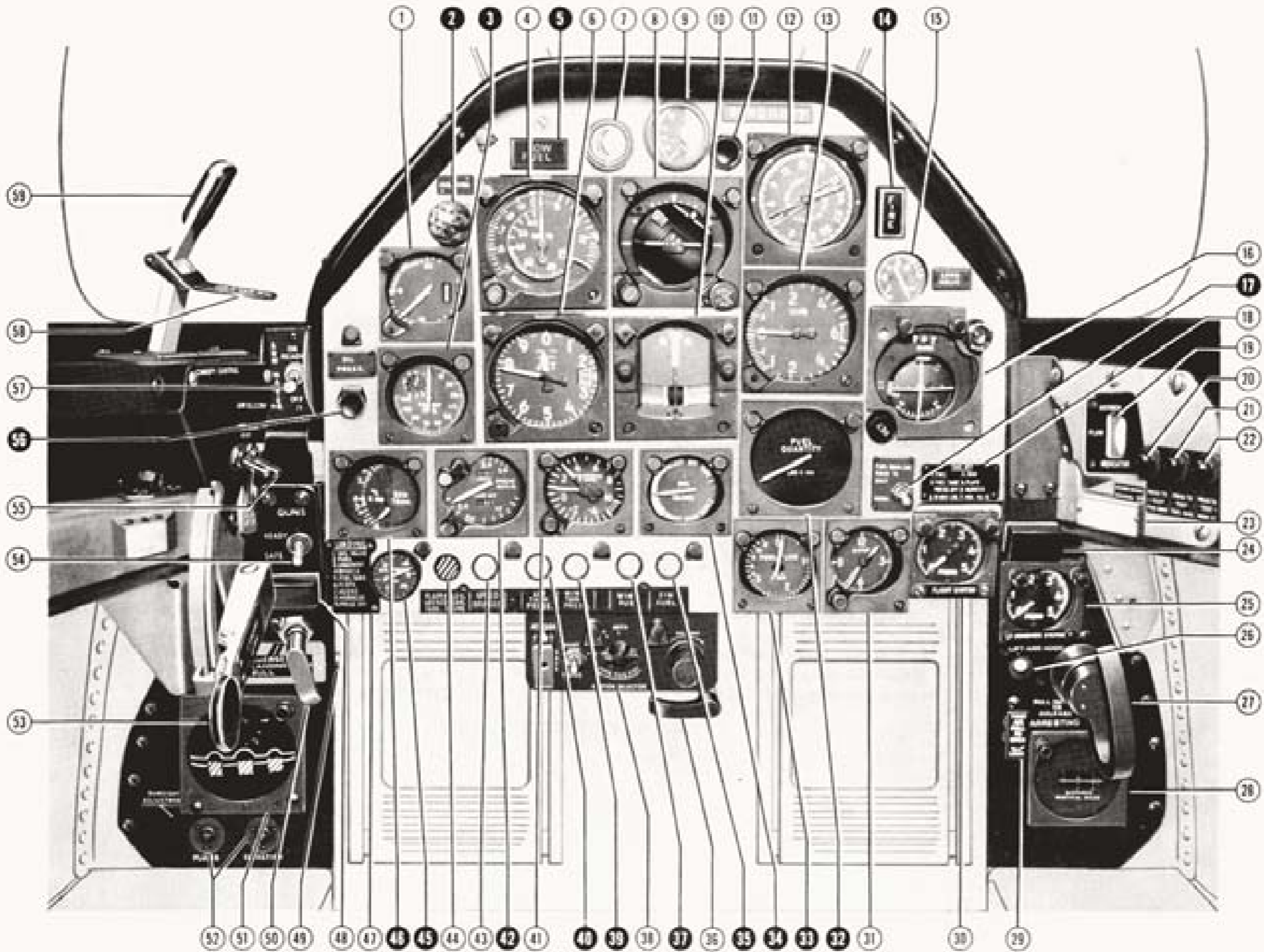

Figure 1-5. Cockpit, Forward—Airplanes BuNo. 138610a Through 138645b

KEY TO FIGURE 1-5

1. Angle of Attack Indicator
2. Ignition Warning Light
3. Tachometer
4. Airspeed-Mach Number Indicator
5. Low Level Fuel Warning Light
6. Altimeter
7. Radar AFC Meter
8. Gyro Horizon Indicator
9. Radar Range Meter
10. Turn and Bank Indicator
11. Radar Tracking Indicator Light
12. Course Indicator—ID-250/ARN
13. Rate of Climb Indicator
14. Fire warning Light
15. Longitudinal Trim Position Indicator
16. Cross-Pointer Course Indicator—ID-249A/ARN
17. Fuel Quantity Check Switch
18. Take-Off Check List
19. Repeater Oxygen Flow Indicator
20. Fire Warning Light Circuit Test Switch
21. Fuel Quantity Indicator Test Switch
22. Warning Lights Test Switch
23. Compass and Airspeed Correction Card
24. Arresting Hook Warning Light
25. Combined System Hydraulic Pressure Gage
26. Arresting Hook Up Control Switch
27. Arresting Hook Down Control Handle
28. Range Indicator—ID-310/ARN
29. Foot Heat Diffuser Control Handle
30. Flight System Hydraulic Pressure Gage
31. Clock
32. Fuel Quantity Indicator
33. Fuel Flow Indicator
34. Fuel Balance Indicator
35. Fin Fuel Indicator
36. Rudder Pedals Adjustment Handle
37. Wing Fuel Indicator
38. External Stores Control Panel
39. Wing Tank Pressure Indicator
40. Aft Tank Pressure Indicator
41. Accelerometer
42. Pressure Ratio Indicator
43. Speed Brakes Position Indicator
44. Slats, Flaps and Elevators Locked Indicator
45. Oil Pressure Indicator
46. Tailpipe Temperature Indicator
47. Landing Check List
48. Landing Gear Warning Light
49. Landing Gear Control Lever Down Lock Release Knob
50. Landing Gear Emergency Control Handle
51. Wheels and Flaps Position Indicator
52. Sight Unit Adjustment Knobs
53. Landing Gear Control Lever
54. Gun Control Switch
55. Gun Selection Switches
56. Oil Pressure Warning Light
57. Armament Master Switch
58. Jettison Locking Lever
59. Canopy Control Lever

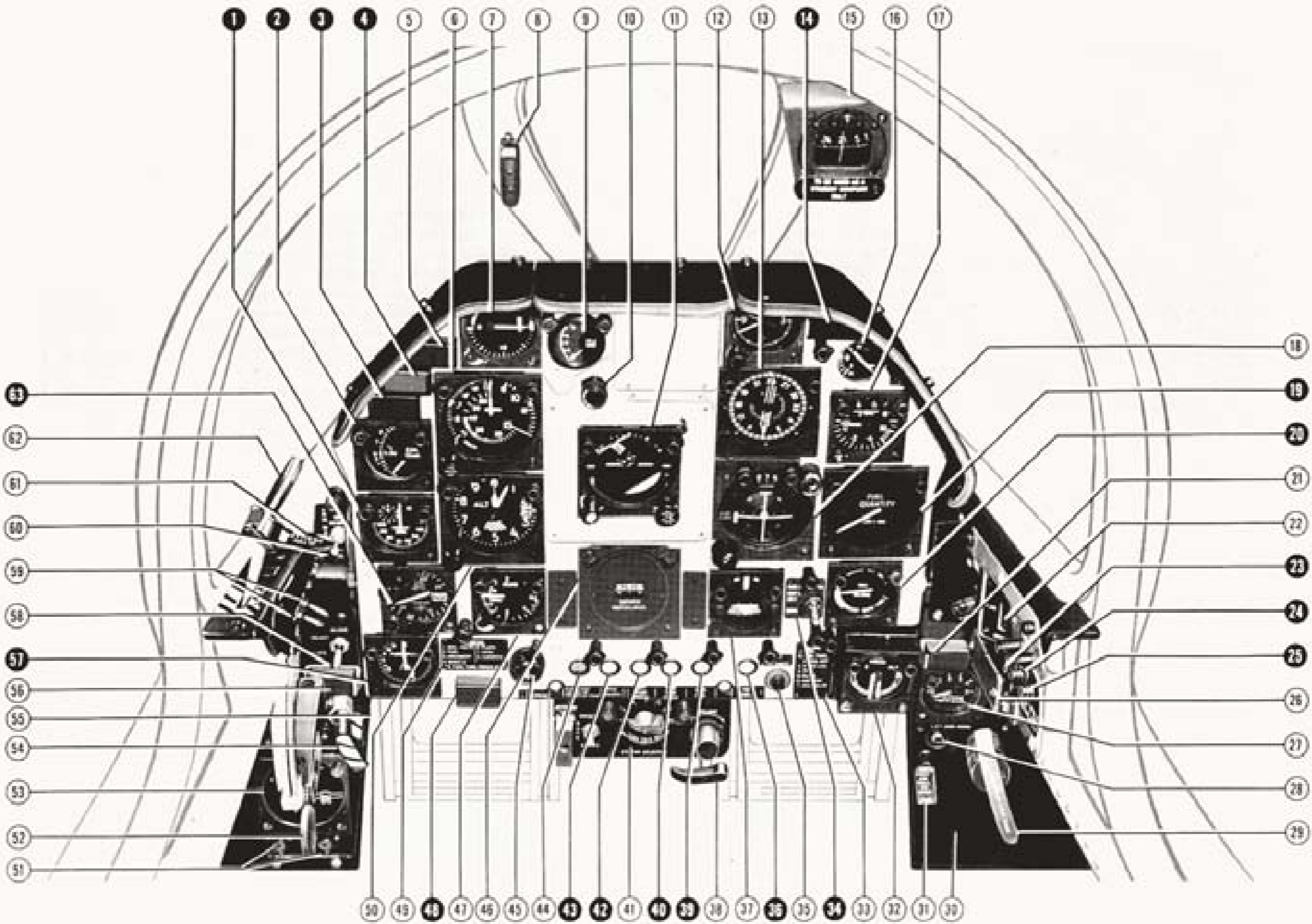

Figure 1-5A. Cockpit, Forward—Airplanes BuNo. 141728c and Subsequent



KEY TO FIGURE 1-5A

- |  |   |
|--|---|
| 1. Tachometer  | 31. Foot Heat Diffuser Control Handle                 |
| 2. Tailpipe Temperature Indicator  | 32. Dual Hydraulic Pressure Gage                      |
| 3. Oil Pressure Warning Light  | 33. Take-Off Check List                               |
| 4. Ignition Warning Light  | 34. Fuel Quantity Check Switch                        |
| 5. Wheels Warning Light  | 35. Gyro Fast Erect Switch                            |
| 6. Airspeed-Mach Number Indicator  | 36. Fin Fuel Indicator                                |
| 7. Angle of Attack Indicator (Airplanes BuNo. 138640b and Subsequent)      | 37. Turn and Bank Indicator                           |
| 8. Angle of Attack Light Assembly (Airplanes BuNo. 138640b and Subsequent) | 38. Rudder Pedals Adjustment Handle                   |
| 9. Radar Range Meter   | 39. Wing Fuel Indicator                               |
| 10. Radar Tracking Indicator Light   | 40. Wing Tank Pressure Indicator                      |
| 11. Gyro Horizon Indicator   | 41. External Stores Control Panel                     |
| 12. Clock  | 42. Aft Tank Pressure Indicator                       |
| 13. Course Indicator—ID-250/ARN  | 43. Speed Brakes Position Indicator                   |
| 14. Fire Warning Light   | 44. Slats, Flaps and Elevators Locked Indicator       |
| 15. Stand-By (Magnetic) Compass  | 45. Oil Pressure Indicator                            |
| 16. Longitudinal Trim Position Indicator                                   | 46. Range Indicator—ID-310/ARN                        |
| 17. Accelerometer  | 47. Rate of Climb Indicator                           |
| 18. Cross-Pointer Course Indicator—ID-249A/ARN                             | 48. Low Level Fuel Warning Light                      |
| 19. Fuel Quantity Indicator  | 49. Landing Check List                                |
| 20. Fuel Balance Indicator   | 50. Altimeter   |
| 21. Arresting Hook Warning Light   | 51. Sight Unit Adjustment Knobs                       |
| 22. Repeater Oxygen Flow Indicator   | 52. Landing Gear Control Lever                        |
| 23. Fire Warning Light Circuit Test Switch                                 | 53. Wheels and Flaps Position Indicator               |
| 24. Fuel Quantity Indicator Test Switch                                    | 54. Landing Gear Emergency Control Handle             |
| 25. Warning Lights Test Switch   | 55. Landing Gear Control Lever Down Lock Release Knob |
| 26. Compass and Airspeed Correction Cards                                  | 56. Landing Gear Warning Light                        |
| 27. LOX Quantity Gage  | 57. Fuel Flow Indicator                               |
| 28. Arresting Hook Up Control Switch                                       | 58. Gun Control Switch                                |
| 29. Arresting Hook Down Control Handle                                     | 59. Gun Selection Switches                            |
| 30. deleted  | 60. Armament Master Switch                            |
|  | 61. Jettison Locking Lever                            |
|  | 62. Canopy Control Lever                              |
|  | 63. Pressure Ratio Indicator                          |

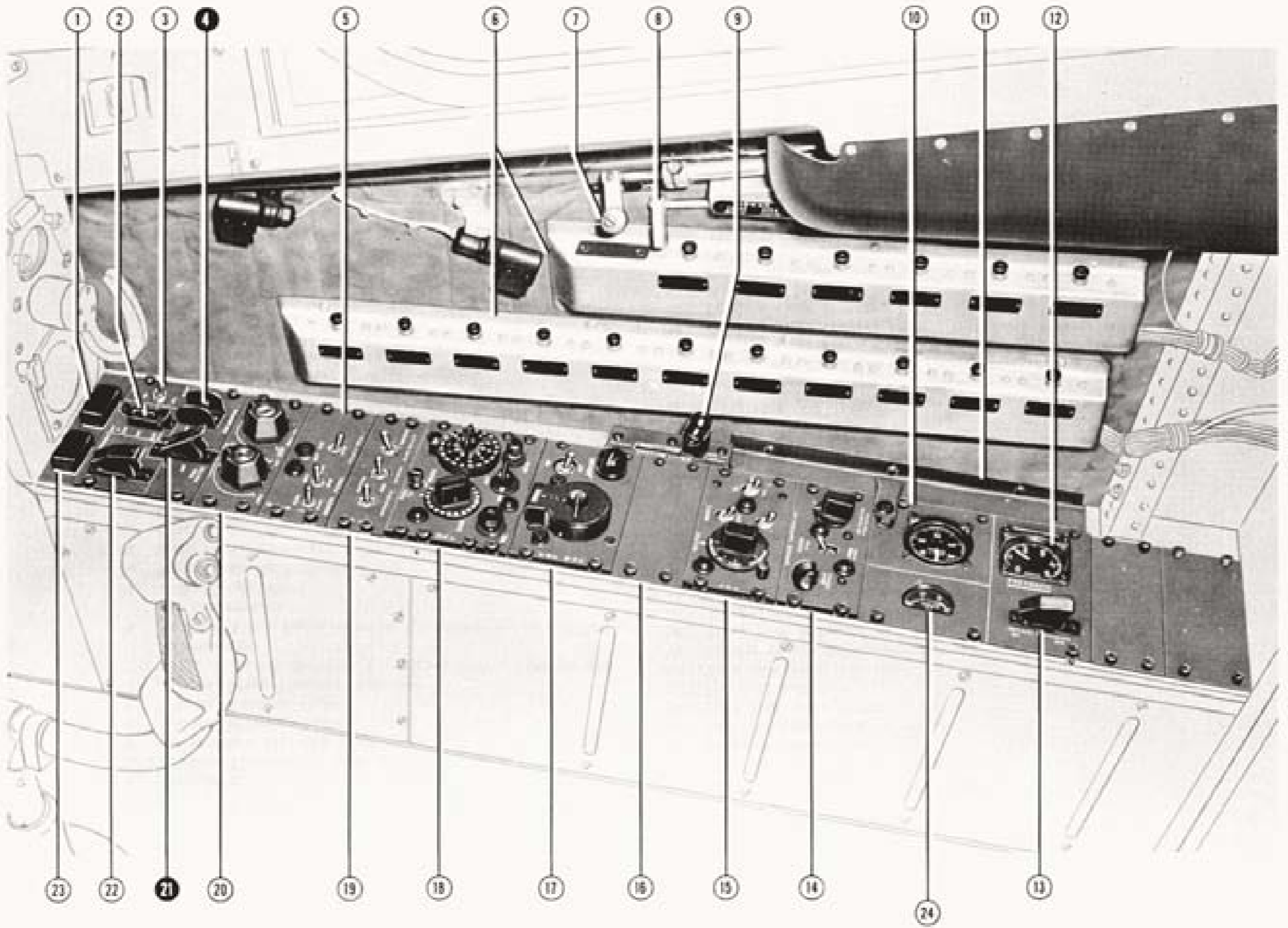

Figure 1-6. Cockpit, Right Side

KEY TO FIGURE 1-6

1. Generator Warning Light
2. D-C Power Switch
3. Pitot Heater Switch
4. Engine Master Switch
5. Exterior Lights Control Panel
6. Circuit Breaker Panels
7. Canopy Defroster Control Handle
8. Cockpit Air Diffuser Control Handle
9. Hydraulic System Isolation Control Lever
10. Cockpit Pressure Altimeter (Airplanes BuNo. 138610a through 138645b)  
Voltmeter (Airplanes BuNo. 141728c and Subsequent)
11. Map Case
12. Pneumatic Pressure Gage
13. Daylight Floodlights Switch
14. S-2 Remote Compass Control Panel (Airplanes BuNo. 138610a through 138645b)  
MA-1 Compass Control Panel (Airplanes BuNo. 141728c and Subsequent)
15. IFF Control Panel—AN/APX-6B
16. Cipher Control Panel—AN/APA-89
17. VHF Navigation Control Panel—AN/ARN-14E or  
UHF Navigation Control Panel—AN/ARN-21
18. UHF Communications Control Panel—AN/ARC-27A
19. Interior Lights Control Panel
20. Air Conditioning System Control Panel
21. Fuel Master Switch
22. Instrument Power Switch
23. Instrument Power Warning Light
24. Voltmeter (Airplanes BuNo. 138610a through 138645b)

1. Daylight Floodlights (4)
2. Headrest
3. Face Curtain Handle
4. Emergency Ejection Seat Arming Handle
5. Cockpit Pressure Dump Valve Control Knob
6. Harness Inertia Reel Control Handle
7. Bucket Height Control Handle
8. Bombs and Rockets Switch
9. Lateral and Longitudinal Trim Control Switch
10. Spare Switch
11. Lateral Trim Position Indicator
12. Nose Wheel Steering Switch
13. Gun Trigger Switch

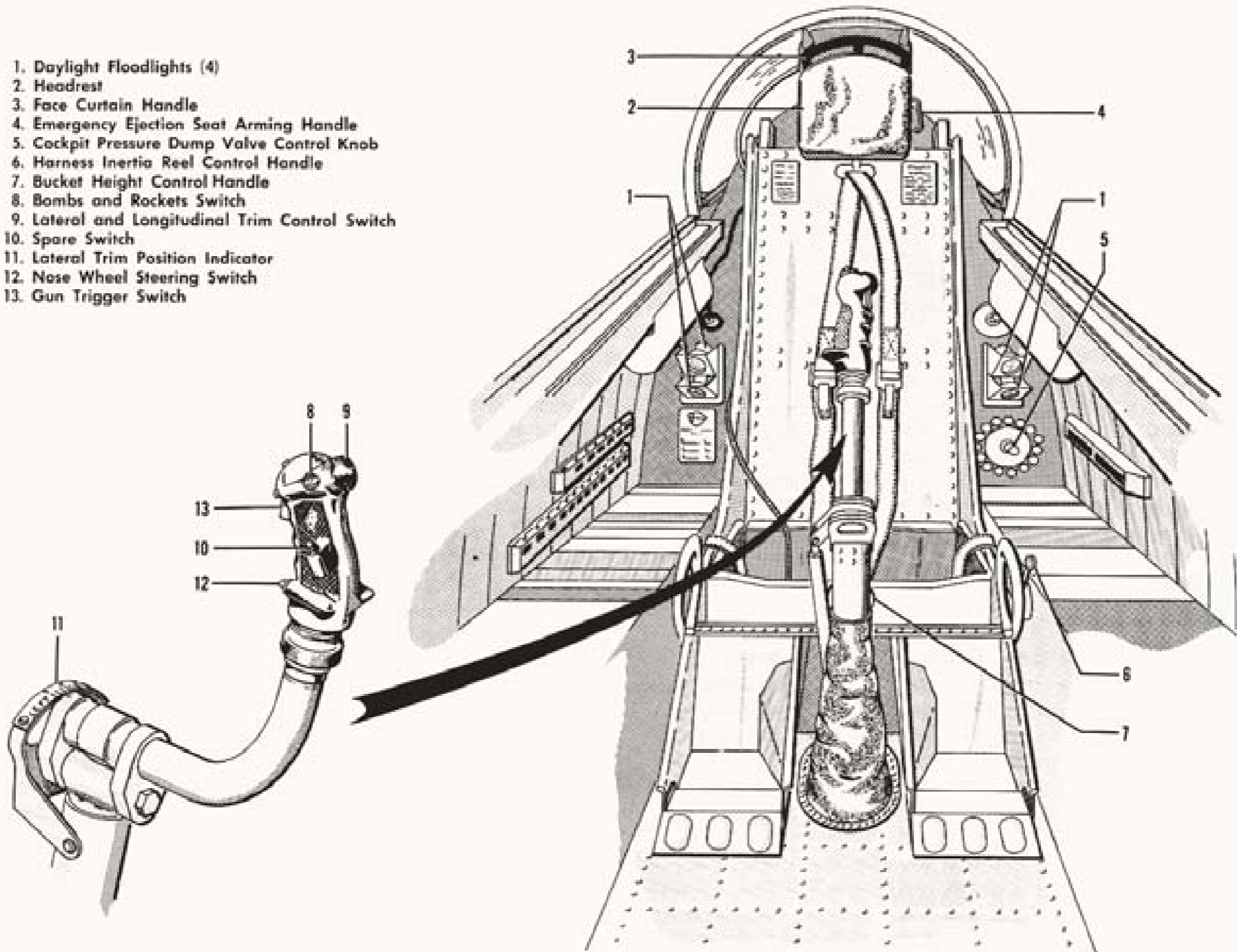

Figure 1-7. Cockpit, Aft

pump warning light on the fuel control panel to illuminate. Failure of the low pressure centrifugal boost pump section (or if the engine is not running, and consequently the pump not operating) will light the low pressure pump warning light on the same panel if the submerged electric boost pump in the main tank is not operating. This light will also glow (when the engine is running) if the element fails and the boost pump cut-off switch is pressed. The fuel control unit automatically governs fuel flow to maintain a constant engine speed at any power control lever setting, regardless of airplane altitude or temperature conditions. It also compensates acceleration fuel flows for variations in compressor inlet airflow to prevent engine stalling and excessive engine temperatures. The unit incorporates an automatic and a manual method of operation, the pilot selection of method being controlled by a toggle switch on the fuel control panel.

#### AUTOMATIC OPERATION.

In automatic operation, fuel flows from the main tank through the engine driven pump to the control unit. In the control unit, fuel flow is regulated by a compressor pressure rise limiter, a regulator valve, pressure and temperature compensating valves, a governor valve and a pressurizing valve. Fuel leaves the control unit and is piped through the six fuel dividers and 36 outlet ports to the main fuel burners.

#### MANUAL OPERATION (EMERGENCY SYSTEM).

Manual operation is selected by the pilot when engine rpm falls off without the power control lever being retarded. When properly monitored, manual operation is as effective, safe and reliable as automatic operation. When manual operation is selected, a solenoid-actuated emergency transfer valve in the fuel control unit operates to route fuel around the automatic functions of the control unit. This supplies fuel directly to the emergency throttle valve. Manual operation is selected by setting the engine fuel control switch to MANUAL. When the switch is in this position, the manual fuel control warning light glows to alert the pilot that he is operating on manual fuel control and does not have the automatic controls functioning and that he is controlling fuel flow directly with the power control lever.

#### CAUTION

The power control lever must be set to IDLE position before switching to manual operation except during operation at take-off. Manual system operation requires constant pilot attention to prevent over-speeding, rich blow-out and excessive temperatures. Fuel flow must be manually controlled continuously to maintain constant rpm and temperatures.

A fail safe fuel control positioner may be installed in accordance with J65 Engine Bulletin 240 (fuel control part No. 19082-11 and subsequent for J65-W-18 engines). The purpose of the device is to provide sufficient power for continued flight in case of a failure of the

power control linkage (i.e., separation of the cockpit power control lever from the engine fuel control unit). On airplanes equipped with this device, the fuel control lever will seek the position which gives  $88 \pm 1\%$  rpm (with fuel control at AUTO). This power setting permits continued flight under most circumstances. On engines not equipped with this device, the fuel control lever will go to an idle power setting. To shut down an engine with a failed power control linkage, move the fuel master switch to OFF. However, the time interval between movement of the switch and initial deceleration varies too much and is too long (12 to 27 seconds) to permit a safe landing with a power-on approach. (See Fuel Boost Pump Emergency Shut-Off Switch paragraph in this section, and see Failure of Power Control Linkage paragraph in Section III.)

### ENGINE FUEL SYSTEM CONTROLS.

#### ENGINE MASTER SWITCH.

The engine master switch (4, figure 1-6) is a two position ON-OFF toggle switch mounted on the electric master panel on the right console. In ON position, it supplies d-c power for operation of the high pressure pump warning light, the engine fuel control selection circuit, the engine fuel control unit solenoid valves, the starter cut-out switch, the ignition system and the primer solenoid.

#### FUEL MASTER SWITCH.

The fuel master switch (21, figure 1-6) is a two position, guarded toggle switch mounted on the electric master panel on the right console. In ON position, it supplies d-c power for operation of the main fuel shut-off valve and the fuel system power relay. The guard must be lifted before the switch can be moved from one position to the other.

#### ENGINE FUEL CONTROL SWITCH.

The engine fuel control switch (13, figure 1-4; or 14, figure 1-4A) is a two position toggle switch mounted on the fuel control panel on the left console. In AUTO position, the automatic system of the engine fuel control unit is operative. In MANUAL position, the automatic controls are by-passed and fuel flow to the engine must be manually controlled by the power control lever.

#### CAUTION

When in MANUAL, fuel flow must be carefully controlled to maintain constant rpm and tailpipe temperatures.

#### BOOST PUMP CUT-OFF SWITCH.

The push-button type boost pump cut-off switch (12, figure 1-4; or 13, figure 1-4A) is mounted on the fuel control panel on the left console. When pressed, it opens the circuit through the fuel boost pump relay and causes the submerged boost pump to stop. This will light the low pressure pump warning light if the engine boost pump is not producing correct pressure.

**CAUTION**

This switch should be used only for a preflight check.

#### BOOST PUMP EMERGENCY SHUT-OFF SWITCH.

The boost pump emergency shut-off switch is installed below the left canopy rail in accordance with F11F Aircraft Service Change No. 116<sup>1</sup>. This switch is installed to provide brief and consistent engine shut-down should power control linkage failure occur before or during the approach to a field landing. (See Failure of Power Control Linkage paragraph in Section III.)

#### ENGINE FUEL SYSTEM INDICATORS.

##### HIGH PRESSURE FUEL PUMP WARNING LIGHT.

The high pressure fuel pump warning light (19, figure 1-4; or 21, figure 1-4A) is a translucent, back-lighted plastic panel in the fuel control panel on the left console. It is illuminated only when the main element of the pump is malfunctioning.

##### LOW PRESSURE FUEL PUMP WARNING LIGHT.

The low pressure fuel pump warning light (21, figure 1-4; or 23, figure 1-4A) is a translucent, back-lighted plastic panel in the fuel control panel on the left console. It is illuminated when both the submerged boost pump in the main tank and the engine driven boost pump fail. The light receives dc from the primary bus, through the instruments circuit breaker, when the d-c power switch is set to BAT. & GEN. or to BAT. ONLY. Prior to starting the engine, operation of the submerged boost pump may be checked by setting the fuel master switch to ON and pressing the boost pump cut-off switch button. The low pressure fuel pump warning light will glow as long as the switch is held depressed and should go out when it is released. While the engine is running, the engine driven boost pump may be checked by pressing the boost pump cut-off switch button and observing that the light does not glow. This is an indication that the engine driven boost pump is delivering the required pressure when the submerged pump is shut off.

**Note**

The use of a single light for the dual purpose described does not permit identification of malfunction. It warns the pilot only of trouble in the low pressure portion of the fuel system. **THE BOOST PUMP CUT-OFF SWITCH SHOULD BE USED ONLY FOR PREFLIGHT CHECK.**

#### FUEL FLOW INDICATOR.

This indicator (33, figure 1-5; or 57, figure 1-5A) is located on the main instrument panel. It has a pointer

which shows the rate of fuel flow in hundred of pounds per hour out of the engine fuel control unit.

#### MANUAL FUEL CONTROL INDICATOR LIGHT.

The manual fuel control indicator (20, figure 1-4; or 22, figure 1-4A) is a translucent, back-lighted, amber plastic panel in the fuel control panel on the left console. It is illuminated when the manual engine fuel control system has been selected.

#### POWER CONTROL LEVER.

The power control lever (10, figure 1-4; or 9, figure 1-4A) is installed in the quadrant on the left console. When it is set full aft and inboard to the OFF position, the engine is shut down, the engine fuel control unit cut-off valve is closed to prevent fuel entering the engine fuel control unit and the ignition is off. When the engine master switch has been set to ON and the power control lever is moved outboard to the START detent, it energizes a solenoid on the external gas turbine compressor. The solenoid opens a valve on the compressor which then supplies air to the starter to crank the engine up to 15% (1245 rpm). The ignition circuit is energized when the power control lever is moved slightly forward (3-5°) from the START detent. When the power control lever is moved forward to IDLE detent, the engine fuel control unit cut-off valve opens and fuel is fed to the burners to operate the engine at the proper idle rpm, approximately 42% (3500 rpm). Moving the power control lever forward from IDLE to NORMAL opens the fuel passages sufficiently to operate the engine at approximately 96.5% (8000 rpm), and moving it further forward from NORMAL to MIL (military) opens the passages to operate the engine at 100% (8300 rpm). A detent outboard of the MIL setting is provided for operating the afterburner. Engaging the power control lever in the detent actuates a switch to start the afterburner operating. Thirteen degrees of power control lever movement are provided within the detent to enable the pilot to modulate rpm and afterburner thrust. (See Afterburner paragraph.)

A three way, thumb operated toggle switch on the inboard side of the grip controls the speed brakes. A momentary push button type microphone switch is installed in the top of the grip and the entire grip rotates to control caging of the sight unit gyro.

#### FRICITION CONTROL LEVER.

A friction control lever (23, figure 1-4; or 24, figure 1-4A) is installed on the inboard side of the quadrant. The lever is moved forward to increase friction on the power control lever, aft to decrease it. It will not completely lock the power control lever.

#### CATAPULT GRIP.

A folding cross bar (11, figure 1-4; or 12, figure 1-4A) is installed across the forward end of the quadrant to

<sup>1</sup>F11F Aircraft Service Change No. 116 can be incorporated on Airplanes BuNo. 138610 through 138645, and BuNo. 141728 through 141884.

enable the pilot to hold the power control lever against the forward stop during catapult take-off. The cross bar can be raised and swung outboard to facilitate pilot's access to forward console controls.

### ENGINE COOLING.

Engine cooling is accomplished by four separate automatic systems. The first uses a portion of the compressor air to cool the combustion chamber liners and the turbine blades. The second bleeds air from the compressor and passes it around the center main and rear main bearings. The third system cools the afterburner by picking up outside air through fuselage ducts and passing it between the blanket shroud and the afterburner. This air exhausts at the rear of the shroud. The fourth system bleeds air from the ram air ducts for cooling of the generator and the engine driven hydraulic pumps.

### IGNITION SYSTEM.

The ignition system is used only for starting. It consists of a limit switch on the quadrant, an ignition unit, a speed switch, a primer solenoid, primer igniters, an ignition warning light and an airstart ignition switch (26, figure 1-4). When the power control lever is moved slightly forward ( $3-5^\circ$ ) from the START detent and with the engine master switch ON, the limit switch is actuated and allows 28 volt dc to pass through the speed switch, the primer solenoid, and the ignition unit to the primer igniters. The speed switch is set to close the primer solenoid and open the ignition circuit at 1900 rpm. When the airstart switch is actuated, it allows 28 volts dc to pass through the ignition unit to the igniters at any rpm. Dc is provided to the primer solenoid simultaneously through the  $3-5^\circ$  throttle switch.

#### Note

Power for the ground starting ignition circuit is available only when the engine control circuit breaker is in and the engine master switch is ON. Power for airstart ignition is available whenever the airplanes d-c primary bus is energized and is obtained by moving the airstart ignition switch to ON.

### IGNITION WARNING LIGHT.

The ignition warning light (2, figure 1-5; or 4, figure 1-5A), located on the main instrument panel, glows whenever the normal or airstart ignition system is turned on. During ground starts, it will also light as the power control lever is slightly advanced from OFF and will go out as the starting air supply shuts off, approximately 20 seconds later. See Airstart Procedure in Section III.

### CAUTION

If, under emergency conditions, the ignition system is allowed to remain on more than

two minutes at any one time, an engine hot section inspection will be required.

### STARTING SYSTEM.

The ground starting system consists of an air turbine starter installed on the front end of the engine shaft. A duct leads from the starter to the left wheel well and an adapter and end cap are mounted on the end of the duct. The starter is rotated by a blast of air from a ground starting compressor unit which is coupled to the starter duct at the adapter. The compressor unit contains a shut-off valve to stop the compressed air supply when the starter reaches a predetermined cut-off speed (2500 rpm). The compressor unit shut-off valve is opened by a solenoid which is energized when the power control lever is placed in the START detent. There is no separate air starting system. Airstarts are accomplished by supplying fuel and ignition to the windmilling engine (see Airstarts paragraph in Section III). Starts can be aborted by closing the throttle and turning off the engine master switch.

### ENGINE INDICATORS.

#### TACHOMETER.

The tachometer (3, figure 1-5; or 1, figure 1-5A) is located on the main instrument panel. It is powered by the tachometer generator and indicates engine rpm in percentage of military rpm ( $100\% = 8300$  rpm). The dial is numbered in tens from 0 to 100. A small pointer rotates over a sub-dial which shows graduations in one per cent of engine rpm to provide more accurate readings than the large pointer.

#### TAILPIPE TEMPERATURE INDICATOR.

This indicator, marked EXH. TEMP., (46, figure 1-5; or 2, figure 1-5A) is located on the main instrument panel and is numbered from 0 to 10. To determine the tailpipe temperatures in degrees centigrade, multiply the dial markings by 100. The indicator is actuated by 12 thermocouples installed in the tailpipe.

#### PRESSURE RATIO INDICATOR.

This indicator (42, figure 1-5; 63, figure 1-5A), located on the instrument panel, shows the ratio of turbine discharge total pressure to compressor inlet total pressure, which is a function of engine thrust. This pressure ratio, with the engine properly stabilized, will provide an indication of the relative level of thrust available for take-off for various ambient conditions.

The system operates on 115 volt 400 cycle power from the instrument a-c bus through a fuse<sup>1</sup> located in a junction box in the nose section or the pressure ratio circuit breaker<sup>2</sup> in the a-c circuit breaker panel.

### AFTERBURNER SYSTEM.

The afterburner system provides a means of obtaining maximum thrust for short periods of time by burning

<sup>1</sup>Airplanes BuNo. 138610a through 138645b.

<sup>2</sup>Airplanes BuNo. 141728c and subsequent.

additional fuel injected into the afterburner chamber to increase existing exhaust gas temperatures. Raising the exhaust gas temperature increases the velocity of the gases which, in turn, produces higher thrust. The afterburner accomplishes this without exceeding the allowable temperature limits of the turbine. The afterburner system includes the afterburner chamber, afterburner element of the fuel pump, afterburner fuel control unit, hot streak ignition, a momentum switch, hydraulic pump, two position nozzle, nozzle solenoid valve, the nozzle actuators and the afterburner switch that is actuated by the power control lever and an afterburner nozzle override switch (located on the console aft of the power control lever quadrant). Afterburner operation is selected by placing the power control lever into the AFTERBURNER detent located outboard of the MIL position on the quadrant.

#### AFTERBURNER CHAMBER.

This assembly is fastened to the engine aft of the turbine and incorporates a fuel manifold which supplies fuel to the afterburner nozzles and a flame holder which serves to stabilize combustion and supply a continuous source of ignition.

#### AFTERBURNER FUEL CONTROL UNIT.

The afterburner fuel control unit is a servo operated, hydro-mechanical control which meters fuel to the afterburner as a function of engine compressor discharge pressure. In addition, movement of the power control lever while in the afterburner detent enables the pilot to modulate rpm and afterburner thrust.

#### HOT STREAK IGNITION SYSTEM.

The hot streak ignition system provides hot streak injection without damage to turbine inlet stator blades. This is accomplished by using two fuel injectors located on the upstream side of the turbine. Flow to the injectors is controlled by a solenoid valve. The solenoid valves are energized by d-c power from the primary bus, via the power control lever actuated afterburner switch, auxiliary relay and the momentum switch. Fuel from the engine fuel control unit is supplied to the hot streak injection system and is ignited by the hot exhaust gases produced by the engine. When afterburner light-up is accomplished, the hot streak ignition is turned off automatically by the momentum switch. It is also turned on automatically in the event of an afterburner flame-out. The system is deactivated when the gun trigger switch is depressed, to prevent the afterburner from cycling when the guns are fired.

#### TWO POSITION NOZZLE.

The two position nozzle consists of a rigid circular outer shell and a movable, segmented inner section. The outer shell is connected to the inner section by means of a sys-

tem of cams. Four hydraulic actuators, controlled by a solenoid valve which is energized through the momentum switch, move the outer shell forward and aft. Aft movement of the outer shell opens the inner section by means of the cams to increase nozzle area; forward movement of the outer shell closes the inner section to decrease nozzle area. Control of the two position nozzle is either automatic or manual but the nozzle cannot be stopped in an intermediate position.

On some airplanes,<sup>1</sup> should afterburner blow-out occur during gunfiring, the nozzle will be held open to permit operation at higher altitudes without compressor stall. See High Altitude Gunfire Induced Compressor Stalls, Overtemperatures and Afterburner Blow-outs paragraph, Section VII.

On early airplanes<sup>2</sup>, automatic nozzle control is achieved by placing the three position afterburner nozzle override switch (25, figure 1-4; or 5, figure 1-4A) in AUTO, which energizes the afterburner momentum (pressure) switch circuit. In case of malfunction of the momentum switch, manual control of the nozzle can be achieved by use of the OPEN or CLOSE positions of the nozzle override switch. If it is necessary to use the afterburner with a malfunctioning momentum switch, the following steps must be taken:

- a. Set nozzle override switch to AUTO.
- b. Place power control lever in afterburner detent.
- c. As soon as there is indication of afterburner light-off, move nozzle override switch to OPEN.
- d. If the exhaust gas temperature starts to exceed limits (which is an indication that the nozzle did not open), immediately move the power control lever out of the afterburner detent and the nozzle override switch to AUTO.

Perform step d. when it is desired to secure afterburner operation and return to basic engine power. It is recommended that operation of the afterburner with a malfunctioning momentum switch be kept to a minimum because the "hot streak ignition" fuel is continuously injected, with the possibility of local heat damage to the turbine inlet stator vanes.

This three position switch in normal operation is effective only when the power control lever is in the afterburner detent. Whenever the power control lever is moved out of the afterburner detent, the nozzle will always close regardless of the position of the nozzle override switch (unless the nozzle is mechanically jammed open).

#### Note

When the nozzle override switch is positioned to CLOSE, the afterburner is shut off even if the power control lever is in the afterburner detent.

<sup>1</sup>Airplanes BuNo. 141751d and subsequent.

<sup>2</sup>Airplanes BuNo. 138610a through 141750c.



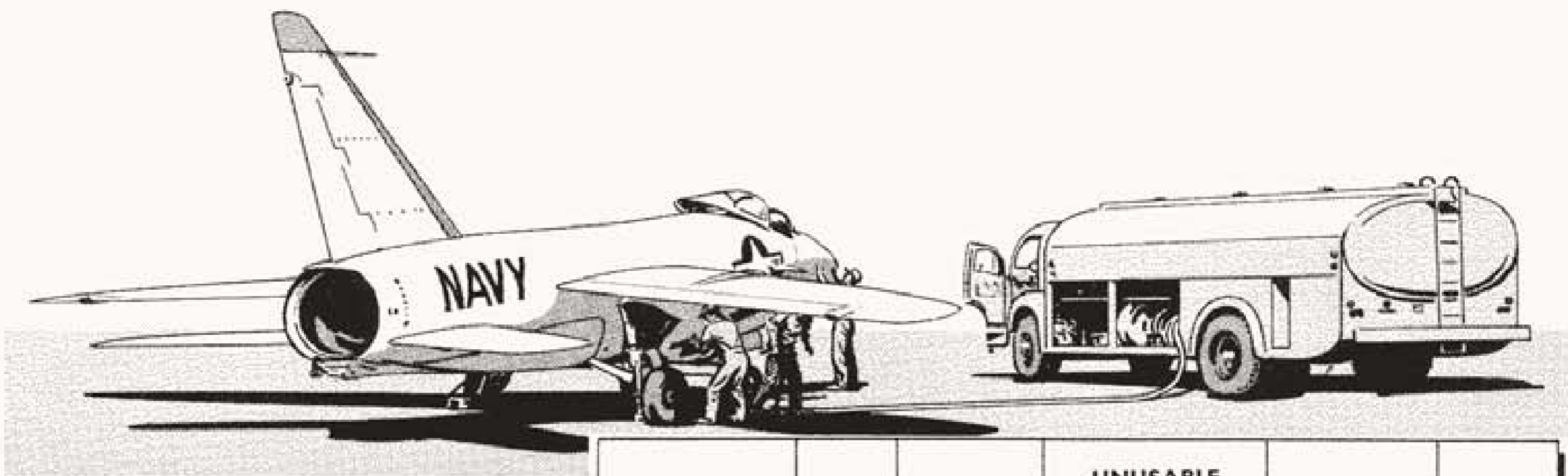

**FUEL  
QUANTITY  
DATA**

**(US GALLONS)**

TANKS	NO.	USABLE FUEL NORMAL FLIGHT ATTITUDE	UNUSABLE FUEL (trapped in tank and lines) NORMAL FLIGHT ATTITUDE	EXPANSION SPACE	TOTAL VOLUME
Main	1	512	3	19	531
Aft	1	272	4	0	272
Fin	1	50	0	3	53
Wing	2	191	1	2	193
Droppable	2	300	2.6	9.4	309.4

Figure 1-7A. Fuel Quantity Data Table

On some airplanes<sup>1</sup>, automatic nozzle control is achieved only when the two position afterburner nozzle override switch is in NORMAL.

**WARNING**

When the two position nozzle override switch is set to OPEN, the afterburner nozzle will open. This position of the switch is effective even if the power control lever is not in the afterburner detent. A serious loss of power and possible engine overspeed may occur if this switch is inadvertently positioned to OPEN. In doing so, the afterburner is shut off even if the power control lever is in the afterburner detent, and the basic engine will not develop proper thrust because of the open nozzle. The OPEN position of this switch should be used only during low rpm ground operation for checking operation of the after-

burner nozzle, or as a means of minimizing turbine damage if exhaust gas temperature begins to exceed limits while starting the engine.

On later airplanes<sup>2</sup>, automatic nozzle control is achieved only when the two position nozzle override switch is in NORMAL.

**WARNING**

The same warning as described above applies, except that if the afterburner is lighted prior to moving the nozzle override switch to OPEN it will remain in operation. In case of a malfunction of the momentum switch and if it is desired to operate the afterburner in flight, the following steps must be taken:

- a. Set nozzle override switch to NORMAL.
- b. Place power control lever in afterburner detent.
- c. As soon as there is indication of afterburner light-off, move nozzle override switch to OPEN.

<sup>1</sup>Airplanes BuNo. 141751d through 141816f.

<sup>2</sup>Airplanes BuNo. 141817f and subsequent.

d. If the exhaust gas temperature starts to exceed limits (which is an indication that the nozzle did not open), immediately move the power control lever OUT of the afterburner detent and reposition the nozzle override switch to NORMAL. Perform step d. when it is desired to secure afterburner operation and return to basic engine power.

Electrical failure on all airplanes will turn the afterburner off and close the nozzle.

#### AFTERBURNER OPERATION.

Afterburner operation may be selected by the pilot during any phase of flight to improve airplane speed, rate of climb and maneuvering performance. However, operation should be limited to brief periods of time because fuel is consumed at about three times the consumption rate during military thrust operation. Setting the power control lever into the afterburner detent puts the afterburner in operation. When the power control lever is placed into the afterburner detent, a limit switch in the quadrant is closed to complete a circuit from the d-c primary bus to the afterburner fuel control unit. Direct-current is routed to the hot streak ignition fuel solenoid valve through a pressure type momentum switch. In addition, the momentum switch controls the two position nozzle.

Setting the power control lever into the afterburner detent opens both fuel pump unloading valves in the afterburner fuel control unit and the hot streak ignition fuel valve. This action supplies ignition and fuel to the afterburner, resulting in a light-off. The momentum switch senses this light-off, because of increased pressures due to afterburner combustion, and closes a circuit to actuate an auxiliary relay. Actuation of this relay shuts off the hot streak ignition system and energizes the two position area nozzle actuator solenoid valve. This valve is then opened to direct hydraulic fluid to the two position nozzle actuators to open the nozzle.

The momentum switch also serves to relight the afterburner in the event of a blowout by sensing the decrease in pressure due to the loss of combustion. When the static pressure reaches a critical point, the momentum switch opens, deenergizing the auxiliary relay. When this relay is deenergized, hot streak ignition is supplied to relight the afterburner and the two position nozzle is closed.

#### CAUTION

Caution must be used in initiating afterburning during engine acceleration. Afterburning is not to be initiated below 95% (7900) engine rpm. Throttle manipulation during afterburner operation below 95% rpm causes a vibration which may be recognized as a "honking" sound.

The switch in the afterburner detent should not be actuated manually by the insertion of any instrument into the detent.

#### AFTERBURNER CONTROLS.

##### MOMENTUM SWITCH.

The momentum switch is a pressure operated switch with three pressure pick-offs. When the afterburner is off, the switch is open, but when the afterburner is operating, changes in static pressure cause the switch to close and energize an auxiliary relay. The relay in turn shuts off the hot streak ignition and energizes a solenoid actuated valve, which permits hydraulic fluid to open the nozzle. In the event of an afterburner flame-out, the momentum switch will open to supply hot streak ignition for a re-light and the nozzle will close.

#### OIL SYSTEM.

The engine oil system consists of an oil tank mounted on the upper left side of the compressor housing, an oil pump on the lower left side of the front main bearing support, a scavenge pump mounted on the accessory gear box and a low pressure warning indicator. The oil tank contains an internal pendulum mechanism to insure oil delivery during inverted flight. In addition, the oil pump provides sufficient suction to lift the oil from the tank when the tank outlet is below the level of the pump, as occurs in inverted flight. The oil pump consists of a pressure section and a recirculation section equipped with a strainer. Two metering pumps are attached to, and driven by, the oil pump gearing. The metering pumps feed oil to the center and rear main bearings. This oil lubricates the bearings and is then discharged overboard through vapor manifolds on the center bearing support housing. Oil from the pressure section is pumped through the filter then to the front main bearing, the power take-off box and the afterburner hydraulic pump. The oil going to the afterburner hydraulic pump passes through a filter mounted just aft of the oil pump. Oil from the recirculating section is piped to the bevel gear box, and from there it drains into the accessory gear box. The scavenge pump picks up the oil from the accessory gear box and returns it to the oil tank. Oil consumption is approximately 0.4 US gallons per hour. System capacity is 3.0 US gallons. See figure 1-16 for oil grade and specification.

##### OIL PRESSURE GAGE.

A continuous reading oil pressure gage (45, figure 1-5, or 45, figure 1-5A) is located on the instrument panel. (See Section V for oil pressure limits.)

##### Note

The indicator is installed in a rotated position so that the pointer will fall between 0 and 100 when the gaging system is deenergized.

The 26 volt transformer provides 26 volt, 400 cycle ac for the operation of the gaging system.

##### OIL PRESSURE WARNING LIGHT.

The oil pressure warning light (56, figure 1-5; or 3, figure 1-5A), located on the instrument panel, lights when oil pressure falls below 15 ( $\pm 1\frac{1}{2}$ ) psi.

## AIRPLANE FUEL SYSTEM.

Fuel is carried in bladder type fuselage tanks (main and aft), two integral wing tanks, one fin tank which feeds through the aft tank, and (when installed) two dropable pylon tanks. (See figure 1-8.) The main tank includes two bladder tanks and four cheek tanks, all interconnected. The fin tank and cheek tanks are installed on all airplanes except two.<sup>1</sup> The aft tank is composed of six interconnected bladder cells. See figure 1-2 for general arrangement. In normal operation, all fuel flows to the engine from the main tank through a submerged, electrically driven boost pump. All tanks are pressurized by engine bleed air which transfers fuel from the wing, fin and aft fuselage tanks to the main tank. This automatic fuel transfer system is designed to operate normally without electrical power to maintain the position of the airplane cg within close limits.

On some airplanes,<sup>2</sup> wing tank transfer is electrically withheld until the fin tank fuel is used; but wing tank fuel can be transferred in an emergency by setting the wing fuel transfer switch to EMER. WING TRANS. After fin tank fuel is used, the pilot can retain wing tank fuel and, if drop tanks are installed, drop tank fuel by setting the wing fuel transfer switch to WING HOLD.

On other airplanes,<sup>3</sup> wing fuel is automatically withheld by the fuel head proportioning control until approximately 500 pounds of fuel have been used from the main tank. The pilot can retain wing tank fuel and, if drop tanks are installed, drop tank fuel by setting the wing fuel transfer switch to HOLD.

Retaining wing tank fuel, in conjunction with the wing tank dumping system, permits lightening of the airplane just prior to combat or landing. The weight of fuel (in pounds) in the fuselage tanks is measured by an electronic capacitance type quantity indicating system. Fuel in the wing and fin tanks is not measured. However, each tank is equipped with float switches which actuate a full and empty indicator on the instrument panel. The fuel quantity system also indicates to the pilot the degree of longitudinal unbalance to serve as a check on operation of the automatic transfer system. A fuel quantity indicator is installed to show the total fuel quantity in both the main and aft tanks. A fuel quantity check switch is located on the main instrument panel. When this check switch is placed in the MAIN TK. ONLY position, the fuel quantity indicator shows the amount of fuel in the main tank only. In addition, a fuel balance indicator is installed to show the condition of fuel balance between these tanks. For fuel grade and specification, see figure 1-16, and for fuel quantities, figure 1-7A.

### Note

When the fuel quantity check switch is placed in the MAIN TK. ONLY position, the fuel balance indicator may move in either direction. This movement has no meaning and may be disregarded by the pilot.

### MAIN TANK.

The main tank consists of two bladder type cells interconnected for gravity feed from the upper to the lower cell. Flapper type negative "g" valves are installed on the interconnect fittings to prevent loss of fuel from the lower cell in which the submerged boost pump is located. The upper cell is mounted between the cockpit and the engine accessory compartment and the lower cell is directly below it. A combination pressure fueling shut-off and flow modulating valve is mounted in the upper cell. Fuel vent connections enter the upper cell through the top. The aft connection incorporates a swing check valve to prevent loss of fuel through the vent lines during climbs and catapult take-offs. The upper and lower cells are also connected by intervent lines. Additionally, four metal tanks (cheek tanks), occupying the space between the main inlet and the outside of the airplane, are connected to and function as part of the main tank.

### AFT TANK.

The aft tank consists of six bladder type interconnected cells installed below the engine in the fuselage aft section. Each cell is half "U" shaped and extends from the keel up each side to a point even with the engine centerline. Fuel vent connections enter each forward cell through the top and vent interconnectors join all three cells on each side.

### Note

The airplane fin is an integral fuel tank and, functionally, is an extension of the aft fuselage tank, through which it is fueled and defueled.

### EXTERNAL TANKS

Aero 1C low drag 150 gallon tanks (designed by Douglas and modified by Grumman) can be installed on the wing inboard store station pylons. These tanks function as extensions of their respective wing tanks, and are refueled and defueled through the wing tanks. The tank and pylon fuel system is designed for pressure fueling (at pressure rates up to 50 psi) and transferring operations. Restrictors permit filling of the external tanks first. When a tank is full, further filling is stopped automatically. When the pilot selects wing transfer, fuel flows from the tanks into the wing tank lines and from there to the main tank. During fuel transfer opera-

<sup>1</sup>Airplanes BuNo. 138612a and 138623a.

<sup>2</sup>Airplanes BuNo. 138610a through 138627a and 138629b through 138645b.

<sup>3</sup>Airplanes BuNo. 138628a and 141728c and subsequent.

tions, the tank is pressurized (20 psi) with air. The tanks are equipped with vent valves to protect them during rapid changes in altitude. When the tanks are empty, they remain at their regulated pressure. If the wing dump valves are opened, external tank fuel is dumped along with wing tank fuel. The external tanks can be jettisoned at any time at the pilot's discretion.

#### **FUEL TRANSFER SYSTEM.<sup>1</sup>**

The normal transfer of fuel is from the fin, wing and aft tank (in that order) into the main tank and then to the engine. In normal operation, the fuel tank pressure switch is set to ON and the wing fuel transfer switch to FIN & WING TRANS. position, causing fin tank fuel to be transferred first, followed by wing tank transfer and drop tank, if installed. Finally, fuel is used from the main and aft tanks together, as proportioned by the fuel head control system. (See figure 1-8.)

#### **FUEL TRANSFER SYSTEM.<sup>2</sup>**

In normal operation, the fuel tank pressure switch is set to ON, the wing fuel transfer switch is set to NORMAL and the fuel master switch is set to ON. The normal sequence of fuel transfer is as follows: approximately 500 pounds of fuel are used from the main tank, then the wing tanks and drop tanks (if installed). Subsequent transfer is from fin tank in varying proportions to the main tank until the fin tank is empty (first phase) and then from the aft tank in varying proportions to the main tank (second phase). (See figure 1-8.)

### **WARNING**

No transfer of fuel from wing or aft tanks can occur if fuel tank pressure switch is OFF.

The fuel tank pressure switch should be in the OFF position for all carrier take-offs. For carrier landings, including touch and go, the switch should be in the ON position subject to the weight limitations given in Section V.

For field take-offs and landings, the switch should be in the ON position. In the event of a crash landing, the fuel tank pressure switch should be placed in the OFF position just before landing.

#### **FUEL HEAD PROPORTIONING CONTROL SYSTEM.<sup>3</sup>**

The fuel head proportioning control system, figure 1-8, consists of a fuel head control valve and sensing lines which maintain a varying, predetermined head difference between the main and aft tanks to keep the air-

plane cg within close limits. The valve receives engine bleed air at 11 psi and directs it through the head sensing lines for purging and through a valve control line to open or close the pressure fueling shut-off and flow modulating valve in the main tank. The fuel head control valve senses the air and head pressures of each tank and is set to maintain a predetermined varying differential between the two tanks. As pressures deviate from the established differential, the valve admits or excludes the airflow to close or open the modulating valve, thereby excluding or admitting aft tank fuel. As aft tank fuel is permitted to flow into the main tank, the gradual loss of aft tank fuel head creates a greater head difference between tanks than the desired schedule. When the valve senses this difference, it passes 11 psi air pressure to the modulator valve to close it, allowing only main tank fuel to be used. This continues until the desired head differential is exceeded in the opposite direction. The valve then opens and aft tank fuel again flows into the main tank. The transfer rate from fin, wing and drop tanks is 50 gpm maximum. At engine demand flow rates below this amount, the excess transfer flow will tend to fill the main tank, but overfilling is prevented by action of the pilot valve which closes the modulating valve. At engine demand flow rates above 50 gpm, main tank fuel is used to supplement the transfer fuel. As this process continues, the head control valve detects an unbalance between main and aft tanks and permits aft tank fuel to transfer until balance is restored.

#### **FUEL HEAD PROPORTIONING CONTROL SYSTEM.<sup>4</sup>**

The fuel head proportioning control system, figure 1-8, consists of a two phase fuel head control valve and sensing lines which maintain a varying, predetermined head difference between the main and fin tanks in the first phase and the main and aft tanks in the second phase, to keep the airplane fuel balance within close limits. The valve receives regulated engine bleed air at 15 psi and directs it through a valve control line to open or close the pressure fueling shut-off and flow modulating valve in the main tank. The fuel head control valve senses the air and head pressures of each tank and is set to maintain a predetermined varying differential between the main and fin tanks in the first phase and the main and aft tanks in the second phase. As pressures deviate from the established differential, the valve admits or excludes the airflow to close or open the modulating valve, thereby excluding or admitting fin or aft tank fuel. As fin or aft tank fuel is permitted to flow into the main tank, the gradual loss of fuel head creates a greater head difference between the tanks than the desired schedule. When the valve senses this difference, it passes 15 psi air pressure to the modulator valve to close it, allowing only main tank fuel to be

<sup>1</sup>Airplanes BuNo. 138610a through 138627a and 138629b through 138645b.

<sup>2</sup>Airplanes BuNo. 138628a and 141728c and subsequent.

<sup>3</sup>Airplanes BuNo. 138610a through 138627a and 138629b through 138645b.

<sup>4</sup>Airplanes BuNo. 138628a and 141728c and subsequent.

# AIRPLANE FUEL SYSTEM

Airplanes BuNo. 138610a through 138627a and 138629b through 138645b.

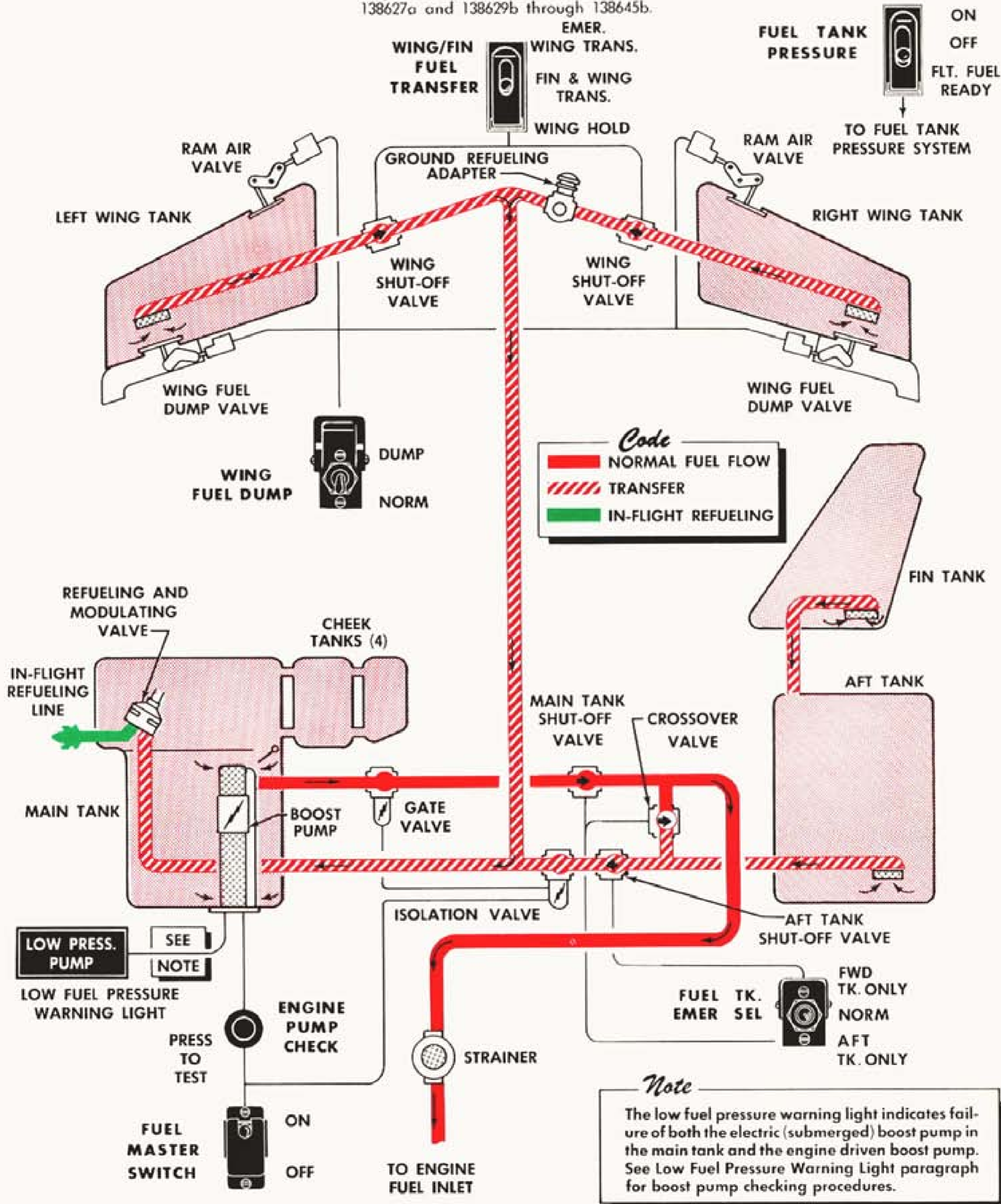

Figure 1-8. Fuel System—Schematic (Sheet 1)

**FUEL TRANSFER — Airplanes BuNo. 138610a through 138627a and 138629b through 138645b**

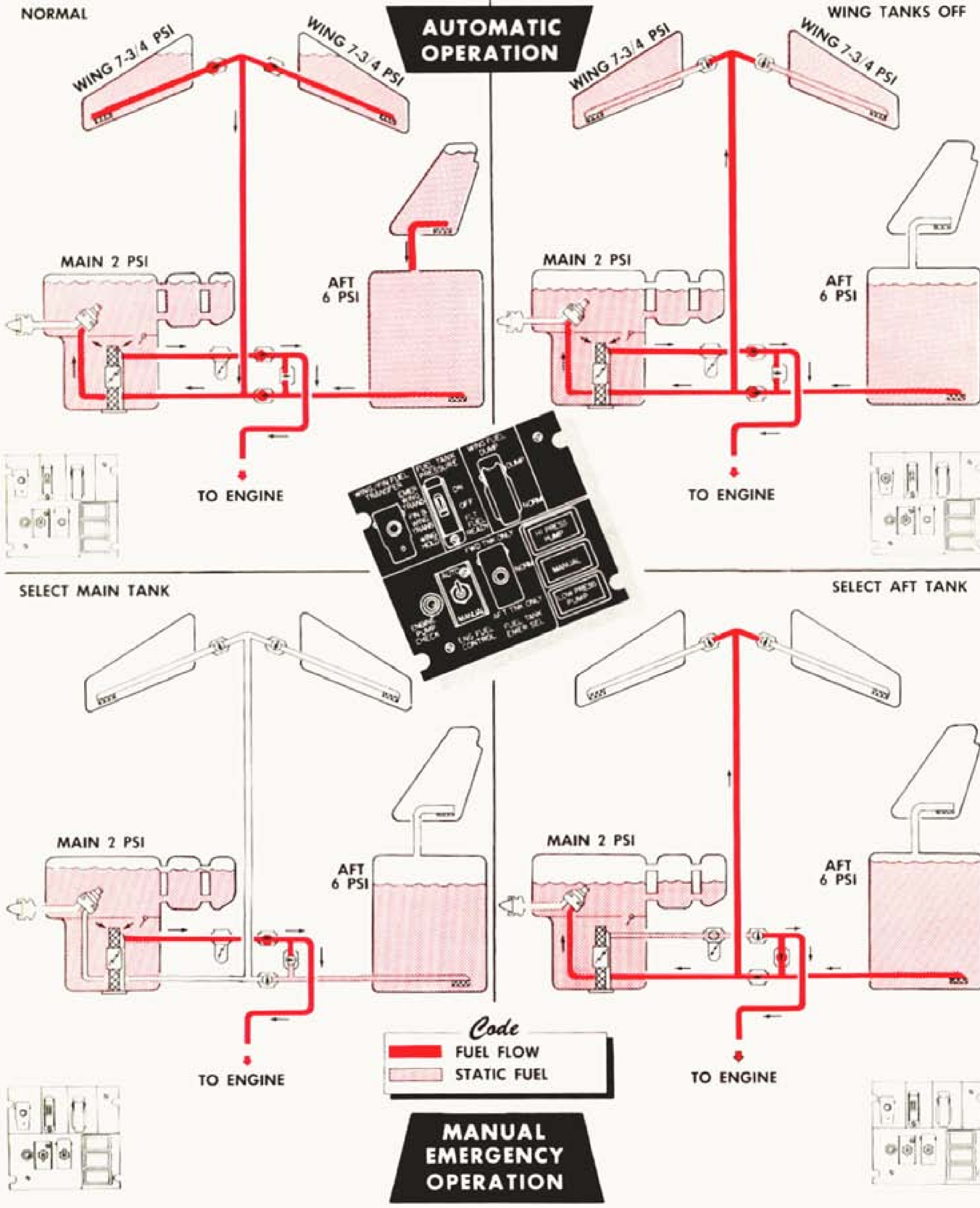

Figure 1-8. Fuel System—Schematic (Sheet 2)

# FUEL TRANSFER — Airplanes BuNo. 138628a, 141728c and Subsequent

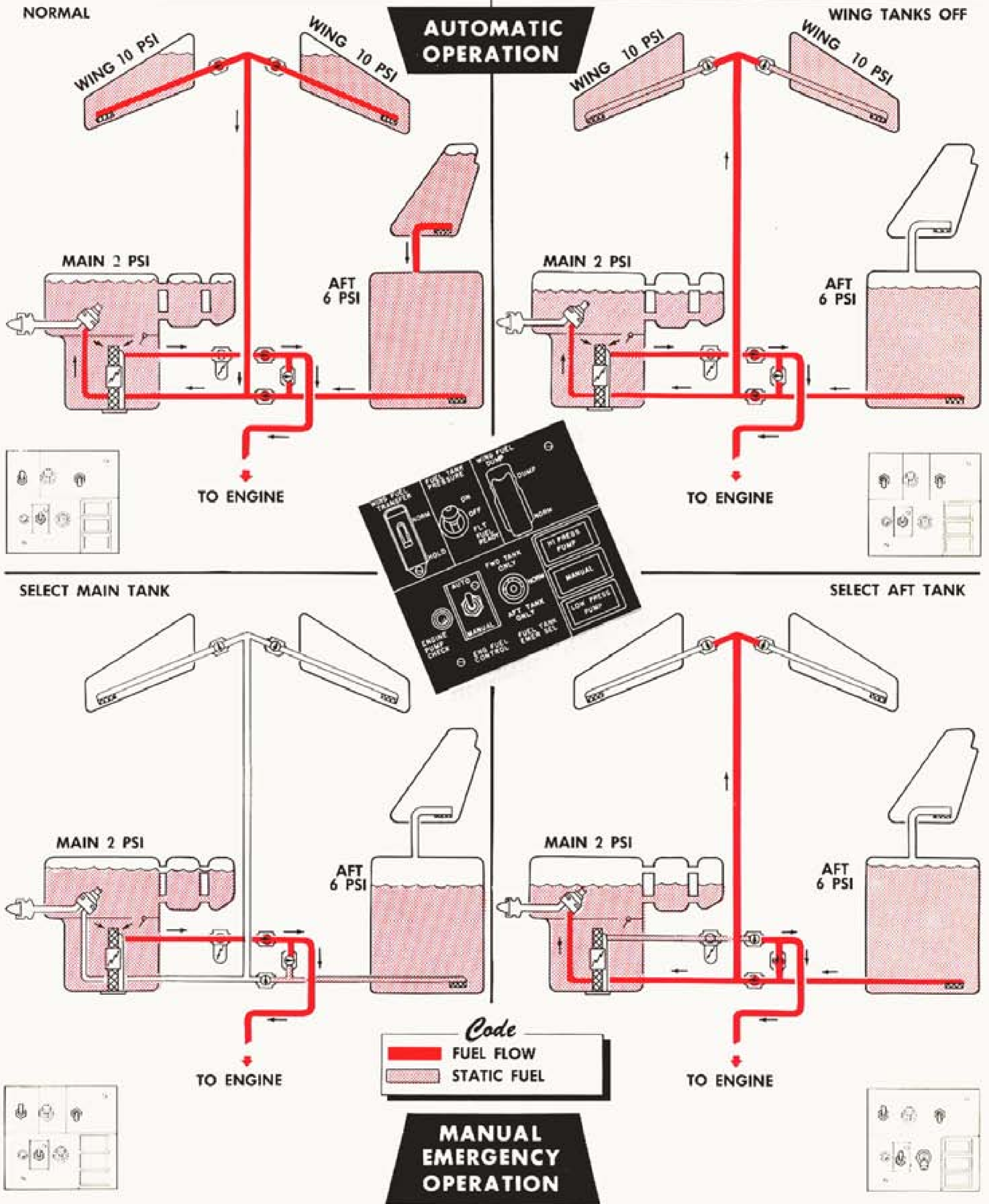

Figure 1-8. Fuel System—Schematic (Sheet 3)

# FUEL HEAD PROPORTIONING CONTROL SYSTEM

Airplanes BuNo. 138610a through 138627a and 138629b through 138645b

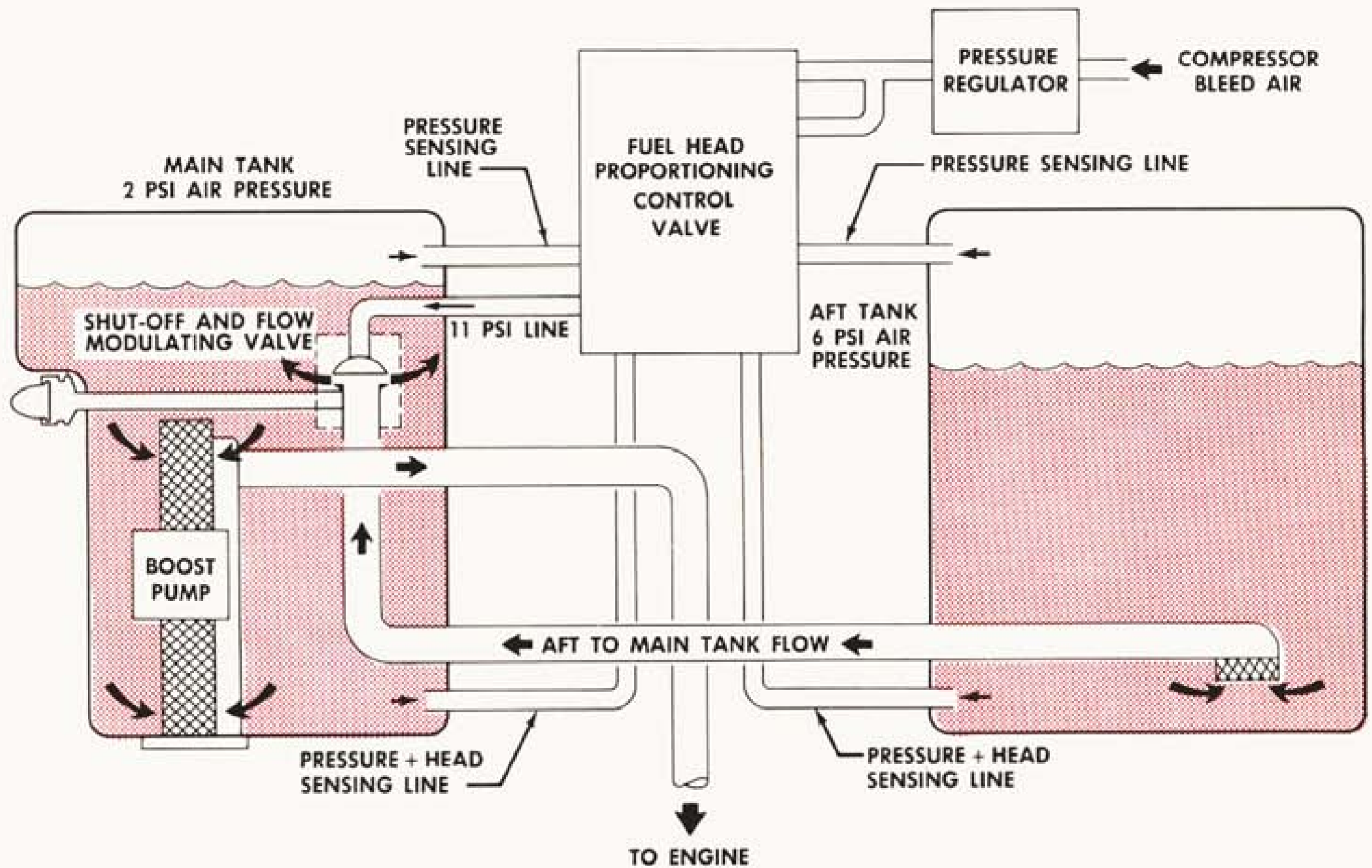

Figure 1-8. Fuel System—Schematic (Sheet 4)

used. This continues until the desired head differential is exceeded in the opposite direction. The valve then opens and fin or aft tank fuel again flows into the main tank. When the fin tank is empty, the first phase of the fuel head proportioning control system is complete and the second phase is automatically entered. The transfer rate from the wing and drop tanks is 50 gpm. However, if engine demand flow rates are below this amount, the modulating valve, whose opening and closing is governed by the fuel heads in the main and aft tanks, will prevent overfilling of the main tank as soon as main tank fuel head is greater than called for in the head control schedule. Overfilling is also prevented by the action of the pilot valve, which closes the modulating valve when the main tank is full. If engine demand flow rates are above 50 gpm, main tank fuel is used to supplement the transfer of fuel. As this process continues, the head control valve detects an unbalance between the main and aft and fin tanks and permits fin

tank fuel or aft tank fuel transfer until balance is restored.

## AUTOMATIC OPERATION OF FUEL SYSTEM.

With the fuel tank pressure switch ON, the pressurizing and vent system maintains proper pressures in the wing, fin, aft, main and drop tanks, if installed. On some airplanes,<sup>1</sup> during fin tank transfer, wing fuel is automatically withheld by a float switch which closes the wing shut-off valves until the fin tank is empty. On other airplanes,<sup>2</sup> wing fuel is automatically withheld by the fuel head proportioning control until approximately 500 pounds of fuel have been used from the main tank.

The wing fuel lines are tee connected into the aft tank transfer line downstream of the dual diaphragm aft tank shut-off valve. This valve is normally open to permit aft-to-main tank flow, but this flow is prevented during wing transfer by the higher pressure of wing fuel on the downstream side of the valve.

<sup>1</sup>Airplanes BuNo. 138610a through 138627a and 138629b through 138645b.

<sup>2</sup>Airplanes BuNo. 138628a and 141728c and subsequent.



# FUEL HEAD PROPORTIONING CONTROL SYSTEM

Airplanes BuNo. 138628a, 141728c and Subsequent

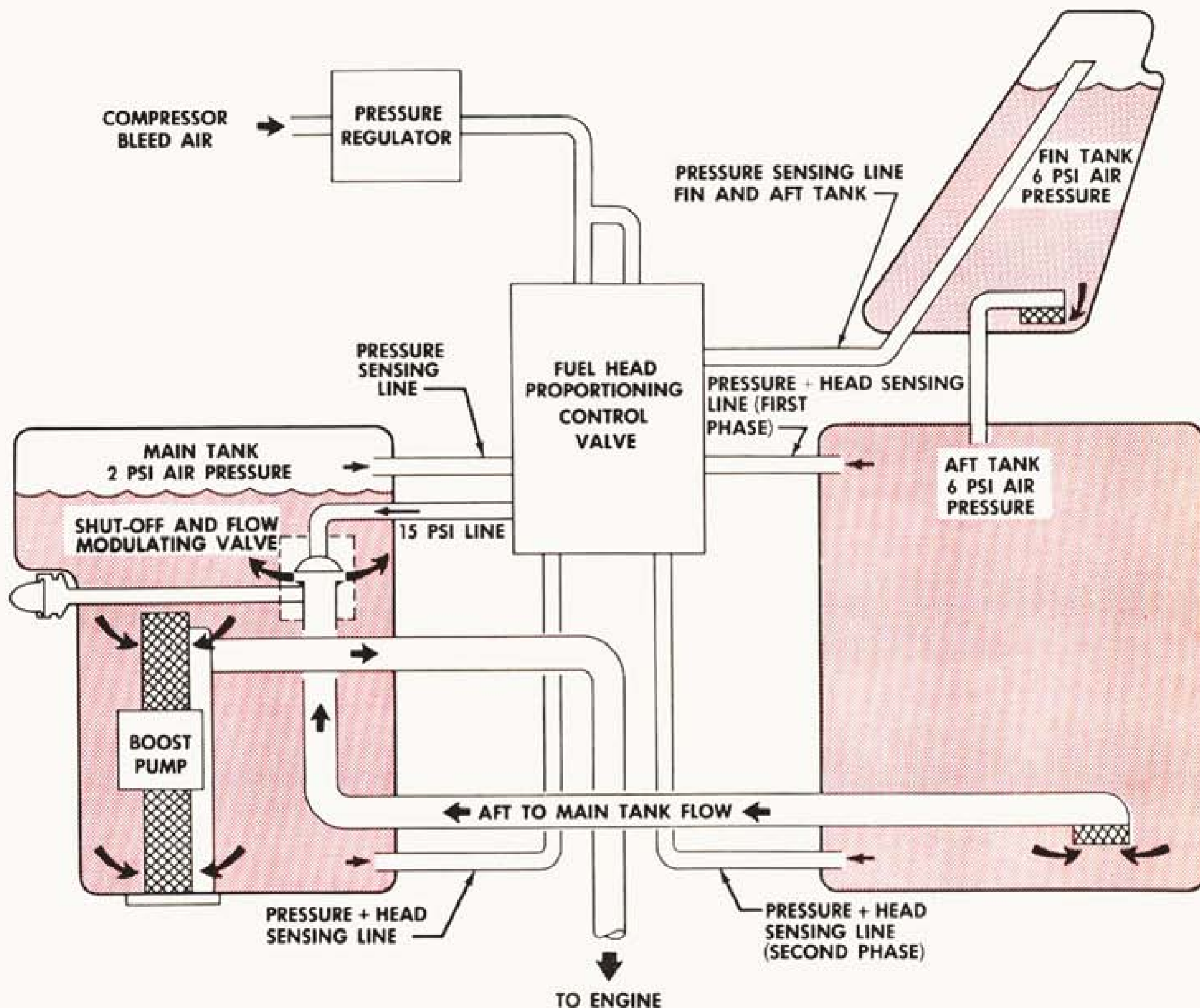

Figure 1-8. Fuel System—Schematic (Sheet 5)

## CAUTION

When decelerating or during let-down, transfer of fuel from the wing tanks is not possible due to the forward motion of the fuel. In addition, the wing fuel indicator will give an erroneous reading of empty rather than a "barber pole" indication when the wing tanks are still half full. Thus, wing fuel quantity indications should be checked only when the airplane is in a climb or cruise condition in order to obtain valid readings.

When wing fuel is exhausted, the wing fuel shut-off valves close and allow aft tank fuel to transfer since

the pressure on the downstream side of the aft tank valve is reduced. This reduction in pressure also occurs if wing fuel is withheld or if the engine demand rate during wing fuel transfer exceeds 50 gpm. When aft tank fuel is exhausted, a float in the valve permits the aft tank pressure to by-pass the diaphragm and exert pressure on the downstream side. This closes the valve and prevents aft tank air from entering the main tank.

## MANUAL EMERGENCY OPERATION.

The fuel quantity indicating system gives an indication on the fuel balance indicator when automatic transfer control has failed and also shows which tank is heavier and must be selected to maintain cg position. The fuel quantity check switch should be placed in the MAIN

TK. ONLY position to cross-check the fuel balance indicator. A fuel tank emergency selector switch permits the pilot to manually select either the main or aft tank. With this system in operation, fuel transfer must be constantly monitored by the pilot. When the fuel tank emergency selector switch is set to MAIN TK. ONLY, aft tank fuel is shut off. When this switch is set to AFT TK. ONLY, the main tank crossover valve is opened and the main tank-to-engine diaphragm shut-off valve is closed. This permits aft tank fuel flow through the crossover and into the engine feed line and shuts off main tank fuel. The manual controls must be used if failure occurs in any component of the head sensing system or the tanks pressurizing system. Regardless of the position of the fuel tank emergency selector switch, an automatic function is provided to allow fuel to flow from the main tank to the engine when the fuel level in the aft tank reaches five gallons or during inverted flight.

### WARNING

If pressure has failed in aft tank, this tank should not be selected above 15000 feet altitude or fuel pump cavitation may result, with subsequent engine flame-out.

#### AIRPLANE FUEL SYSTEM CONTROLS.

##### WING FUEL TRANSFER SWITCH.<sup>1</sup>

The wing fuel transfer switch has three positions: EMER. WING TRANS., FIN & WING TRANS. and WING HOLD. This switch (15, figure 1-4) is mounted on the fuel control panel on the left console. In WING HOLD position, the wing tank shut-off valves are closed and wing fuel is withheld. In FIN & WING TRANS. (which is the normal position), all fin tank fuel is transferred first, followed by wing tank transfer. If wing tanks fail to transfer with the switch in the FIN & WING TRANS. position, use the EMER. WING TRANS. position, but only after the fin tank is empty.

##### WING FUEL TRANSFER SWITCH.<sup>2</sup>

The wing fuel transfer switch has two positions: NORMAL and HOLD. This switch (16, figure 1-4A) is mounted on the fuel control panel on the left console. In the HOLD position, the wing tank shut-off valves are closed in the transfer direction and wing fuel is withheld. In the NORMAL position, transfer of wing tank fuel begins after approximately 500 pounds of fuel have been used from the main tank.

##### FUEL TANK PRESSURE SWITCH.

A three position fuel tank pressure switch (16, figure 1-4; or 17, figure 1-4A) is mounted on the fuel control

panel on the left console. This switch provides ON and OFF control of tank pressure and a third position, FLT. FUEL READY. For normal fuel transfer, the tank pressure switch must be in the ON position. The OFF position closes off air supply to the tanks and energizes solenoids in the relief valves to dump tank pressure. The FLT. FUEL READY position dumps tank pressure in the same way as the OFF position but, in addition, opens the wing and aft tanks fuel shut-off valves to receive fuel in flight. On later airplanes,<sup>2</sup> the FLT. FUEL READY position also energizes the in-flight refueling cobra boom actuator that extends the boom to the refueling position.

#### Note

With the tank pressure switch set to OFF while on the ground, all fuel for engine operation flows from the main tank only. If such operation is prolonged, an unfavorable fuel balance condition may be reached, which will be shown on the fuel balance indicator. Corrective action consists of selecting aft tank only until balance is restored. This also serves as a pre-flight check of the tank emergency selection system.

### WARNING

The fuel tank pressure switch should be in the OFF position for all carrier take-offs. For carrier landings, including touch and go, the switch should be in the ON position subject to the weight limitations given in Section V. For field take-offs and landings, the switch should be in the ON position. In the event of a crash landing, the fuel tank pressure switch should be placed in the OFF position just before landing.

##### FUEL TANK EMERGENCY SELECTOR SWITCH.

The three position fuel tank emergency selector switch (14, figure 1-4; or 15, figure 1-4A) is mounted on the fuel control panel on the left console. In NOR.<sup>3</sup> or NORM.<sup>4</sup> position, fuel transfer is automatic, controlled by the head proportioning system. In MAIN TK. ONLY<sup>3</sup> or FWD. TANK ONLY<sup>4</sup> position, aft tank fuel is shut off and only main tank fuel is supplied to the engine. In AFT TK. ONLY<sup>3</sup> or AFT TANK ONLY<sup>4</sup> position, the main tank fuel is shut off and aft tank fuel can go directly to the engine as well as to the main tank.

<sup>1</sup>Airplanes BuNo. 138610a through 138627a and 138629b through 138645b.

<sup>2</sup>Airplanes BuNo. 138628a and 141728c and subsequent.

<sup>3</sup>Airplanes BuNo. 138610a through 138627a and 138629b through 138645b.

<sup>4</sup>Airplanes BuNo. 138628a, 141728c and subsequent.

**WING FUEL DUMP SWITCH.**

The two position wing fuel dump switch (18, figure 1-4; or 20, figure 1-4A) is mounted on the fuel control panel on the left console. In DUMP position, the wing tank pressure regulators are closed and the dump valves are opened to dump fuel or purge the tanks. In NOR.<sup>1</sup> or NORM.<sup>2</sup> position, the dump valves are closed and the wing tank pressure regulators function to permit normal pressurizing of tanks for fuel transfer.

**AIRPLANE FUEL SYSTEM INDICATORS.****FUEL QUANTITY INDICATOR.**

The fuel quantity indicator (32, figure 1-5; or 19, figure 1-5A) is located on the instrument panel. The dial markings times 100 show the total weight of fuel contained in the aft and main fuselage tanks. The fuel quantity indicator system is powered by ac from the instrument a-c bus, which is energized by either the No. 1 or No. 2 inverter. The a-c circuit is protected by a one ampere circuit breaker in the circuit breaker panel on the left side of the cockpit. D-c power from the primary bus is also utilized to operate the system. The d-c circuit is protected by the fuel gage d-c circuit breaker in the upper circuit breaker panel on the right side of the cockpit. The system is operated by electric capacitance units in each of the fuselage tanks.

**Note**

Fuel varies in weight per gallon, depending upon its specific gravity and temperature. Therefore, the notation "full" does not appear on the indicator dial and the pilot should anticipate variations in the instrument readings when the fuel tanks are full.

**FUEL BALANCE INDICATOR.**

The fuel balance indicator (34, figure 1-5; or 20, figure 1-5A), mounted on the instrument panel, indicates the balance between the fuel quantities in the main and aft tanks to guide the pilot in maintaining airplane cg travel within its forward and aft limits. The indicator dial is marked with an arc which is divided into three segments. The bottom segment is marked SELECT MAIN TANK, the center segment denotes the normal fuel balance and the top segment is marked SELECT AFT TANK. As long as the automatic fuel transfer system is operating normally the indicator pointer will remain within the center (normal fuel balance) segment. If the automatic fuel transfer system fails, the pointer will indicate which tank should be selected on the fuel tank emergency selector switch to regain proper fuel balance. If it is necessary to use the emergency fuel transfer switch, constant monitoring of the fuel balance indicator will be necessary. This indicator operates from signals derived from the fuel quantity indicator system.

**Note**

If the indicator pointer is out of the center (normal) segment only slightly, no immediate corrective action is necessary.

**FUEL INDICATORS TEST SWITCH.**

A push button switch (21, figure 1-5; 24, figure 1-5A) is located on the repeater oxygen blinker panel for checking the operation of the fuel quantity indicating system. With electric power turned on, pushing the switch in causes the pointer on the fuel quantity indicator and the fuel balance indicator to move downscale. If the system is operating properly, the pointers will return to their original positions when the switch is released.

**FUEL QUANTITY CHECK SWITCH.**

A fuel quantity check switch (17, figure 1-5; or 34, figure 1-5A) is located on the instrument panel. This is a two position switch placarded NORM. and MAIN TK. ONLY<sup>1</sup> or MAIN T. ONLY.<sup>2</sup> When in the NORM. position, the fuel quantity indicator shows the total weight of fuel contained in aft and main fuselage tanks and the fuel balance indicator shows airplane condition as affected by fuselage fuel distribution. When in the MAIN TK. ONLY position, the fuel quantity indicator shows the amount of fuel in the main tank only and the fuel balance indicator will not give balance and must be disregarded by the pilot.

**LOW PRESSURE FUEL PUMP WARNING LIGHT.**

See Engine Fuel System Indicators paragraph, this section.

**FUEL TANKS PRESSURE INDICATORS.**

Separate pressure indicators are provided for the wing and aft tanks. Both are barber pole type indicators and are located on the main instrument panel. The wing tank pressure indicator (39, figure 1-5; or 40, figure 1-5A) serves for both right and left tanks since the wing tanks have a common pressure supply source. This indicator reads ON when wing tank pressures are normal and OFF when wing tank pressures are below normal. The aft tank pressure indicator (40, figure 1-5; or 42, figure 1-5A) reads ON when aft tank pressure is normal and OFF when aft tank pressure is below normal. Both indicators show diagonal stripes when electrical power is off.

**WING FUEL INDICATOR.**

This is a barber pole type indicator (37, figure 1-5; or 39, figure 1-5A) on the main instrument panel. It indicates FULL when both wing tanks are full, "red and yellow diagonal stripes" when either tank is less than full, and EMPTY when both tanks are empty.

<sup>1</sup> Airplanes BuNo. 138610a through 138627a and 138629b through 138645b.

<sup>2</sup> Airplanes BuNo. 138628a, 141728c and subsequent.

**FIN FUEL INDICATOR.**

This is a barber pole type indicator (35, figure 1-5; or 36, figure 1-5A) on the main instrument panel. It indicates FULL when the fin tank is full, "barber pole" when the tank is less than full, and EMPTY when the tank is empty.

**LOW LEVEL FUEL WARNING LIGHT.**

A low level fuel warning light (5, figure 1-5; or 48, figure 1-5A) is mounted on the instrument panel. The light illuminates the words LOW FUEL when the weight of fuel in the main tank is 800 ( $\pm 100$ ) pounds.

**IN-FLIGHT REFUELING SYSTEM.**

Starting at the nozzle assembly located in the airplane nose, a two inch aluminum alloy line runs aft, enters the upper main fuel cell and connects to a port in the modulating valve. A check valve in the latter prevents reverse flow of fuel into the in-flight refueling line. A restrictor plate is fitted to the aft side of the check valve. This restrictor, in combination with the restrictor check in the self-sealing disconnect and restrictor valve assembly, serves to proportion the refueling flow between main and aft tanks so that the fuel cg travel is kept to a minimum. Restrictors will also be installed in the wing fuel lines when drop tanks are installed. Fuel shut-off at each tank is controlled by the same valves and switches used for ground refueling. To begin in-flight refueling, the pilot needs only to place the fuel tank pressure switch in the FLT. FUEL READY position. This switch must be returned to the ON position when refueling is completed. See FUEL TANK PRESSURE SWITCH in this section. On later airplanes,<sup>1</sup> a cobra boom (figure 1-8A) extends from the right side of the fuselage forward of the cockpit when the fuel tank pressure switch is set in the FLT. FUEL READY position. After refueling through the boom, and only after the drogue is disengaged, the switch must be returned to the ON position. When this is done, the boom will retract into the fuselage. See In-flight Refueling paragraph, Section VII.

**WARNING**

If switch is placed in ON position while drogue is still engaged, the boom will retract with the drogue and cause extensive damage.

**Note**

During in-flight refueling, the pilot may determine the quantity of fuel taken aboard by communicating with the fueling airplane as well as from the fuel quantity, wing fuel and fin fuel indicators in the cockpit. (Add fuel taken aboard to quantity indicated prior to fueling.)

<sup>1</sup>Airplanes BuNo. 141728c and subsequent.

**COBRA BOOM**

Figure 1-8A. In-flight Refueling Cobra Boom

**ELECTRICAL SYSTEMS.**

The electrical systems are composed of a 28 volt, direct-current system (figure 1-9); a 24 volt, 24 ampere-hour storage battery system; and a three phase, 400 cycle, 115 volt alternating-current system (figure 1-10). An external power receptacle is installed on the left side of the airplane above the wheel well to permit connection of an external d-c power source. The systems are conventional and utilize the airplane as a ground return.

**DIRECT-CURRENT SYSTEM.**

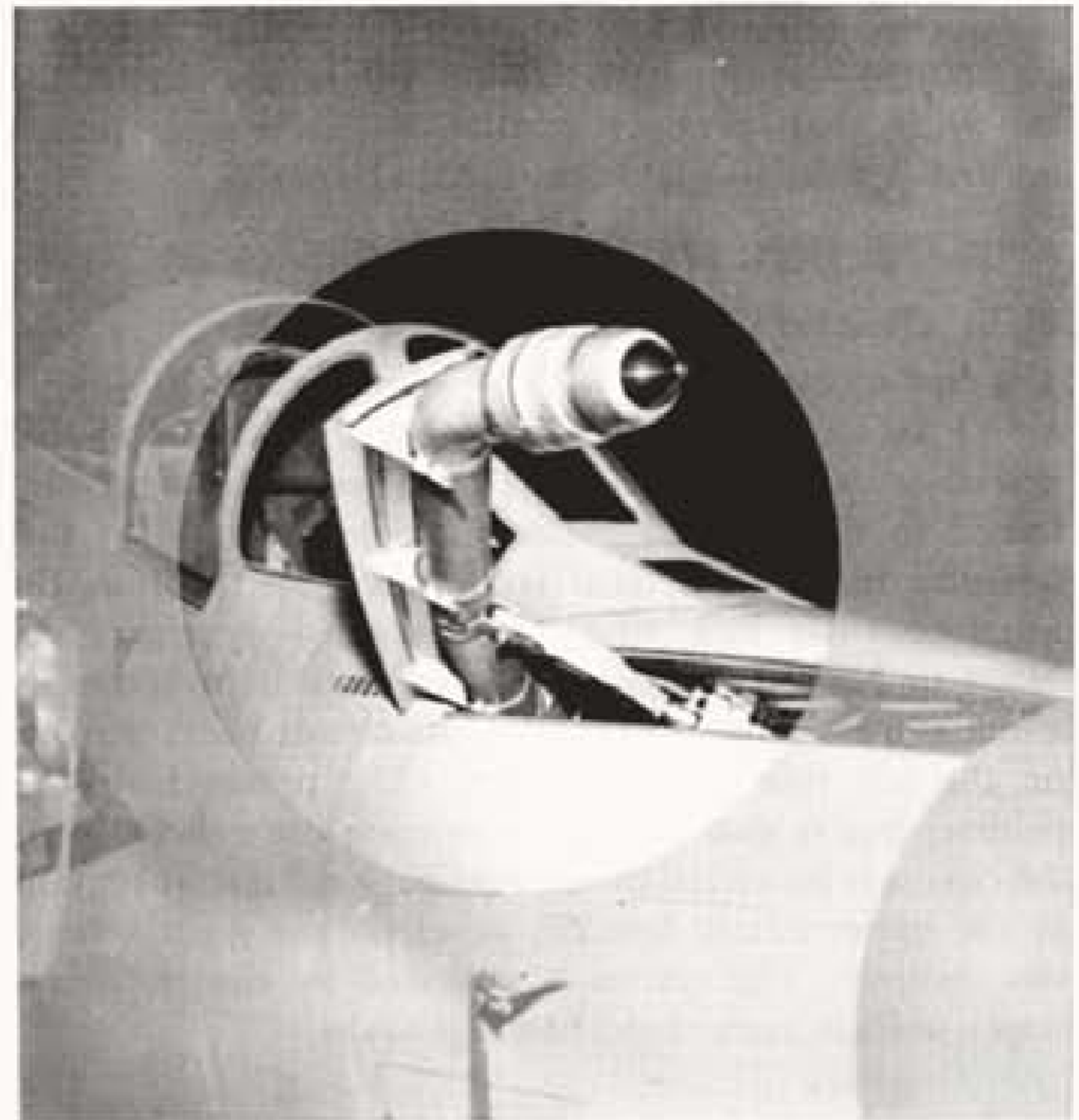
The primary source of d-c power is the engine driven generator and, during normal operation, the generator output, regulated to 27.7 ( $\pm 0.2$  volts), supplies current to all distribution buses (primary, secondary, monitored and battery bus groups). Circuit breakers are installed above the right console (see figure 1-9) for overload protection of circuits important to flight. Other circuits have circuit breakers located in the electrical box on the left side of the nose wheel well and, therefore, are not accessible in flight. Two circuits are connected directly to the battery whenever the d-c power switch is not set to OFF. If the generator should fail in flight (indicated by warning light), the battery will automatically power the primary bus in addition to the circuits directly connected to the battery bus. However,

# D-C ELECTRICAL POWER DISTRIBUTION

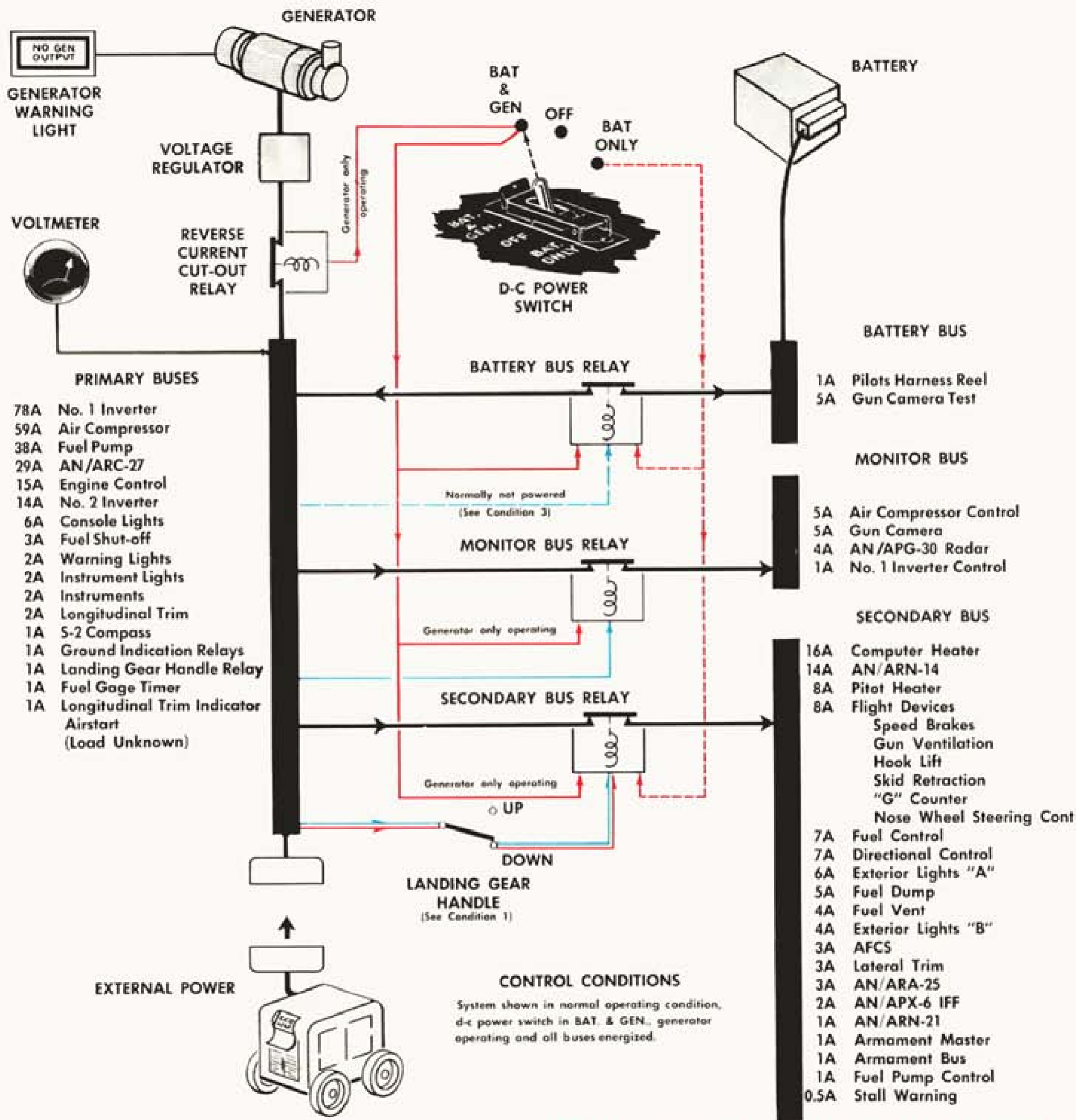

*Note*

Colors indicate separate control circuit selections for relay power.

**2. BAT. ONLY selected.** Battery bus, primary buses, and secondary bus on battery.

**3. External Power (OFF Selected).** Primary buses, monitor bus, and secondary bus on external power; battery bus on battery power. External power can be made available to the battery bus relay (and battery bus) by switching to BAT. & GEN. or BAT. ONLY.

**1. BAT. & GEN. Selected.** All buses on generator. On generator failure, battery power is automatically available to the battery bus and primary buses only. Battery power can be made available to the secondary bus relay (and secondary bus) by lowering the landing gear or by switching to BAT. ONLY (condition 2).

Figure 1-9. D-C Electrical Power Supply System—Schematic

# A-C ELECTRICAL POWER DISTRIBUTION

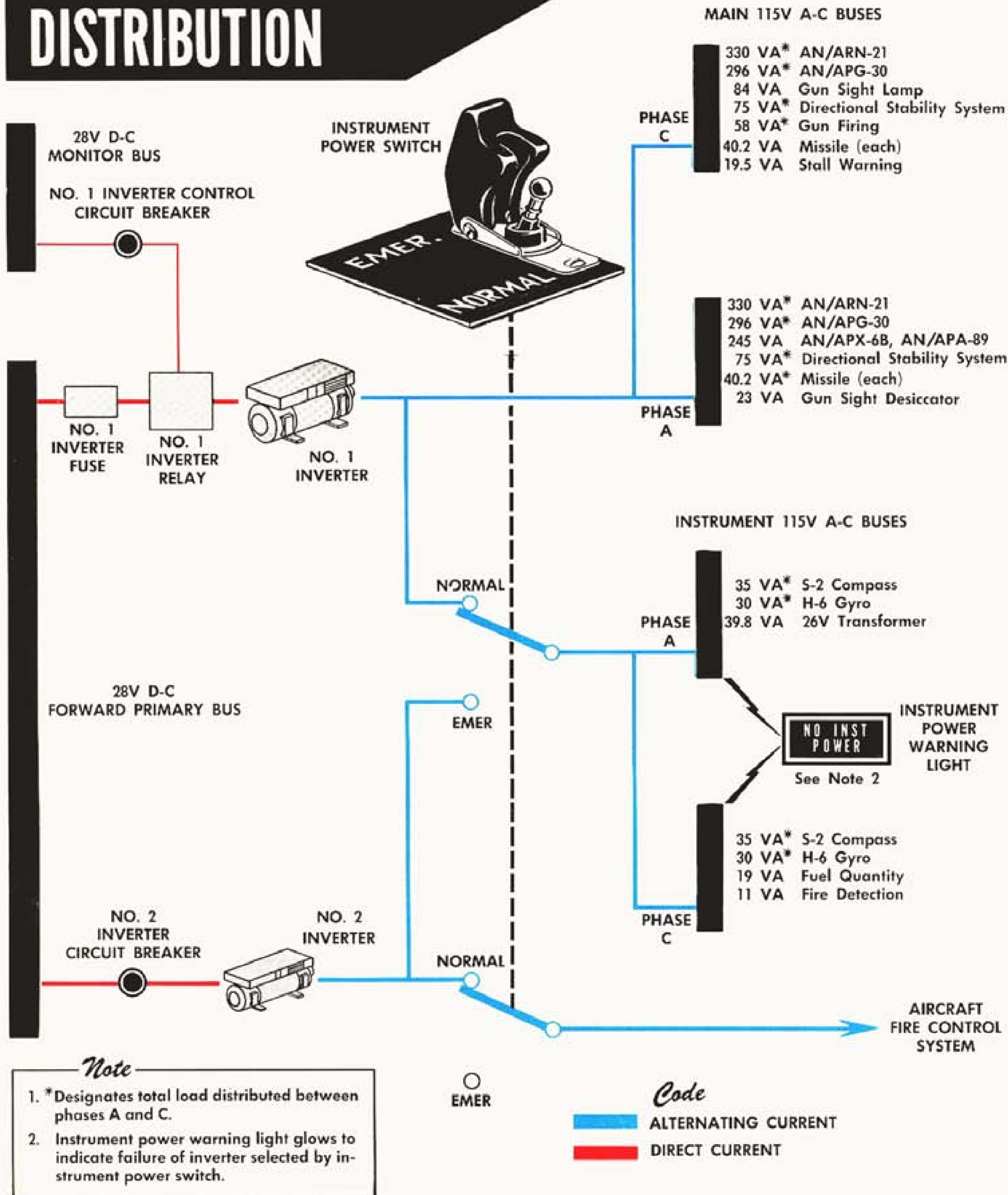

Figure 1-10. A-C Electrical Power Supply System—Schematic

when the landing gear control lever is set to DOWN, the secondary buses are also powered by the battery. Operation by battery power only also may be manually selected by setting the d-c power switch to BAT. ONLY, thus energizing the primary and secondary buses regardless of the position of the landing gear control lever. When external power is connected, all of the buses will be energized if the d-c power switch is in any position other than OFF. When the switch is in OFF position, the battery and battery bus will not be connected to the external power.

#### D-C POWER SWITCH.

This three position switch (2, figure 1-6) is located on the electrical master panel on the right console. In BAT. & GEN. position, generator power supplies all d-c powered systems through their respective buses. If a failure of generator power output should occur while the switch is in this position, the reverse current relay will sense it and cause the battery to assume the loads of the primary bus circuits and, if the landing gear control lever is in DOWN position, the secondary buses also. In OFF position, only the circuits directly connected to the battery receive power. In BAT. ONLY position, the battery powers the primary and secondary and battery buses. Normally, to prevent overcharging and excessive gassing of the battery, this switch should be in the OFF position when external power is connected and it is not desired to operate the system connected to the battery and battery bus.

#### VOLTMETER.

A voltmeter (10 or 24, figure 1-6) is located on the pneumatic panel on the right console. It provides a direct reading of the primary voltage.

#### GENERATOR WARNING LIGHT.

The generator warning light (1, figure 1-6) is located on the electrical master panel beneath a rectangular plastic panel. The light glows whenever the generator is not connected to the airplane's buses. The light illuminates the words NO GEN OUTPUT on the plastic panel.

#### ALTERNATING-CURRENT SYSTEM.

The alternating current system incorporates a No. 1 and No. 2 inverter, both operating continuously. The No. 1 inverter has a rated 1500 va, 400 cycle, 3 phase output; while the No. 2 inverter is rated at 250 va, 400 cycle, 3 phase output. The system includes two groups of buses, the phase A and phase C main a-c buses and the phase A and phase C instruments a-c buses. See figure 1-10 for a tabulation of the circuits and the respective buses from which they derive a-c power.

#### OPERATION.

During normal operation, the No. 1 inverter receives power from the forward primary d-c bus through a 100 ampere fuse and is placed in operation by current from the monitored bus through the No. 1 inverter control circuit breaker. The inverter output is supplied directly to the main a-c buses and, by use of a control

switch and relay, to the instruments a-c buses. The No. 2 inverter is powered by d-c from the primary bus through the No. 2 inverter circuit breaker. Normally, the output of this inverter is available only to the MK 16 Mod 5 aircraft fire control system computing circuits. If the output of the No. 1 inverter fails to reach the instrument a-c buses (as indicated by the instrument power warning light), the control switch may be used to divert the output of the No. 2 inverter to the instrument a-c buses. During this emergency changeover operation, the aircraft fire control system and the circuits supplied by the main a-c buses will be inoperative. The No. 1 inverter remains on the main a-c buses, but since the inverter may have failed, the main a-c buses may not be powered. Should the No. 2 inverter fail during the emergency operation, the instrument power warning light will go on to indicate the lack of power.

#### INSTRUMENT POWER SWITCH.

This two position switch (22, figure 1-6) is located on the electrical master panel. When in NORMAL position, the No. 1 inverter supplies all a-c power requirements for all systems except the MK 16 Mod 5 AFCS computer circuit, which is supplied by the No. 2 inverter. In the EMERG. position, the output of the No. 2 inverter powers the circuits on the instrument a-c buses and the MK 16 Mod 5 AFCS is rendered inoperative. The main a-c buses remain connected to the No. 1 inverter.

#### INSTRUMENT POWER WARNING LIGHT.

The warning light (23, figure 1-6) is located on the electrical master panel and will glow to indicate failure of a-c power to reach the a-c instrument buses. The light illuminates the words NO INST. POWER.

## HYDRAULIC POWER SUPPLY SYSTEMS.

#### NORMAL POWER SUPPLY SYSTEMS.

Two separate and distinctly independent hydraulic power supply systems are provided. The flight system (figure 1-11), supplies power for operation of only the units essential to flight (rudder, stabilizer, and flaperons) while the combined system (figure 1-11), supplies power for operation of the rudder, stabilizer, and flaperons simultaneously with the flight system and, in addition, supplies the speed brakes, flaps and slats, nose wheel steering, elevator shift, wheel brakes, landing gear, arresting hook and tail skid. An isolation valve, controlled by the pilot, installed in the combined system serves to cut off pressure to the flaps and slats, nose wheel steering, elevator shift, wheel brakes and landing gear.

#### Note

The isolation valve does not cut off power to the arresting hook, tail skid, speed brakes, or the flight controls.

Power for each system is supplied by a separate engine driven, variable-volume pump.

# COMBINED HYDRAULIC SYSTEM SCHEMATIC

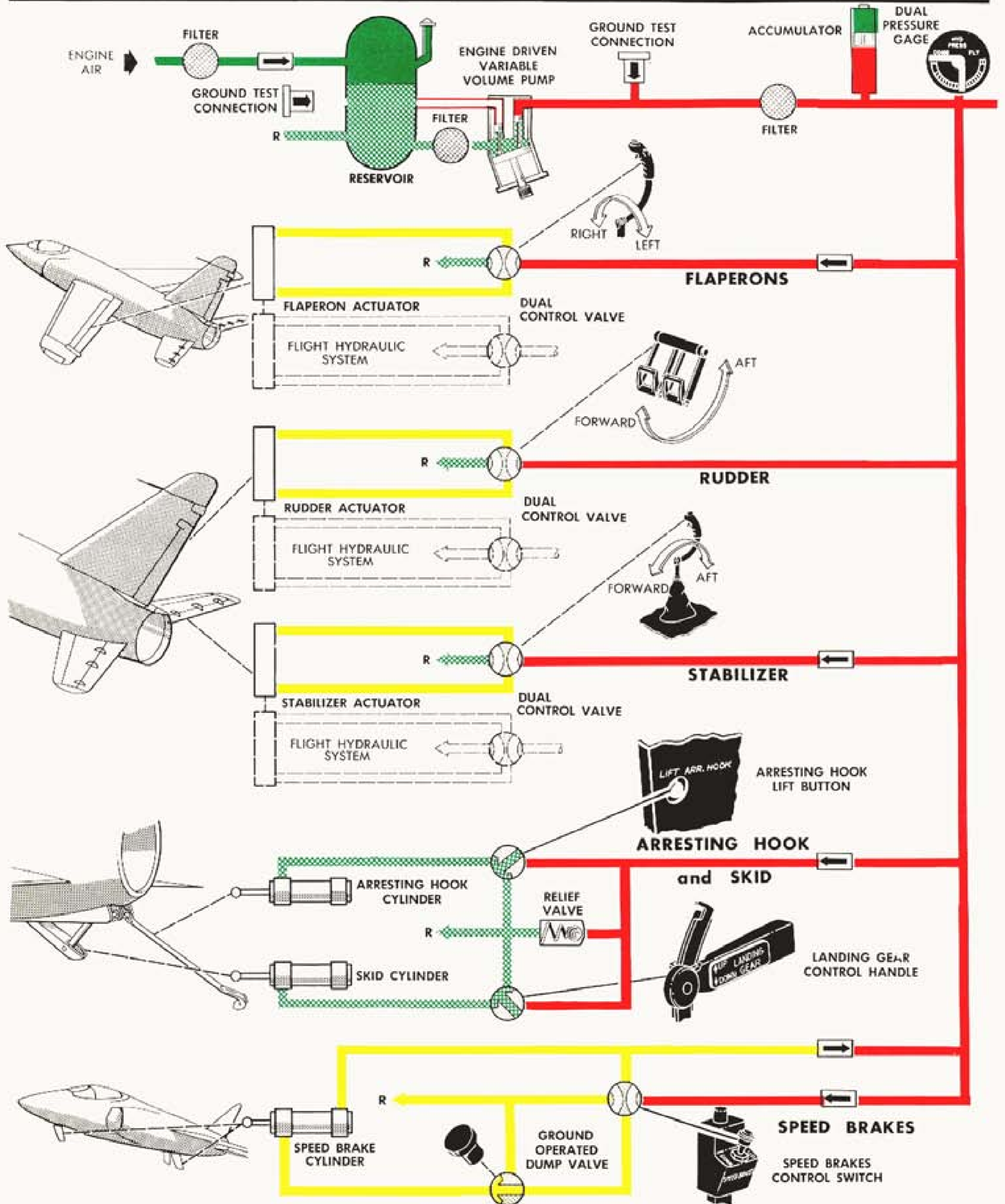
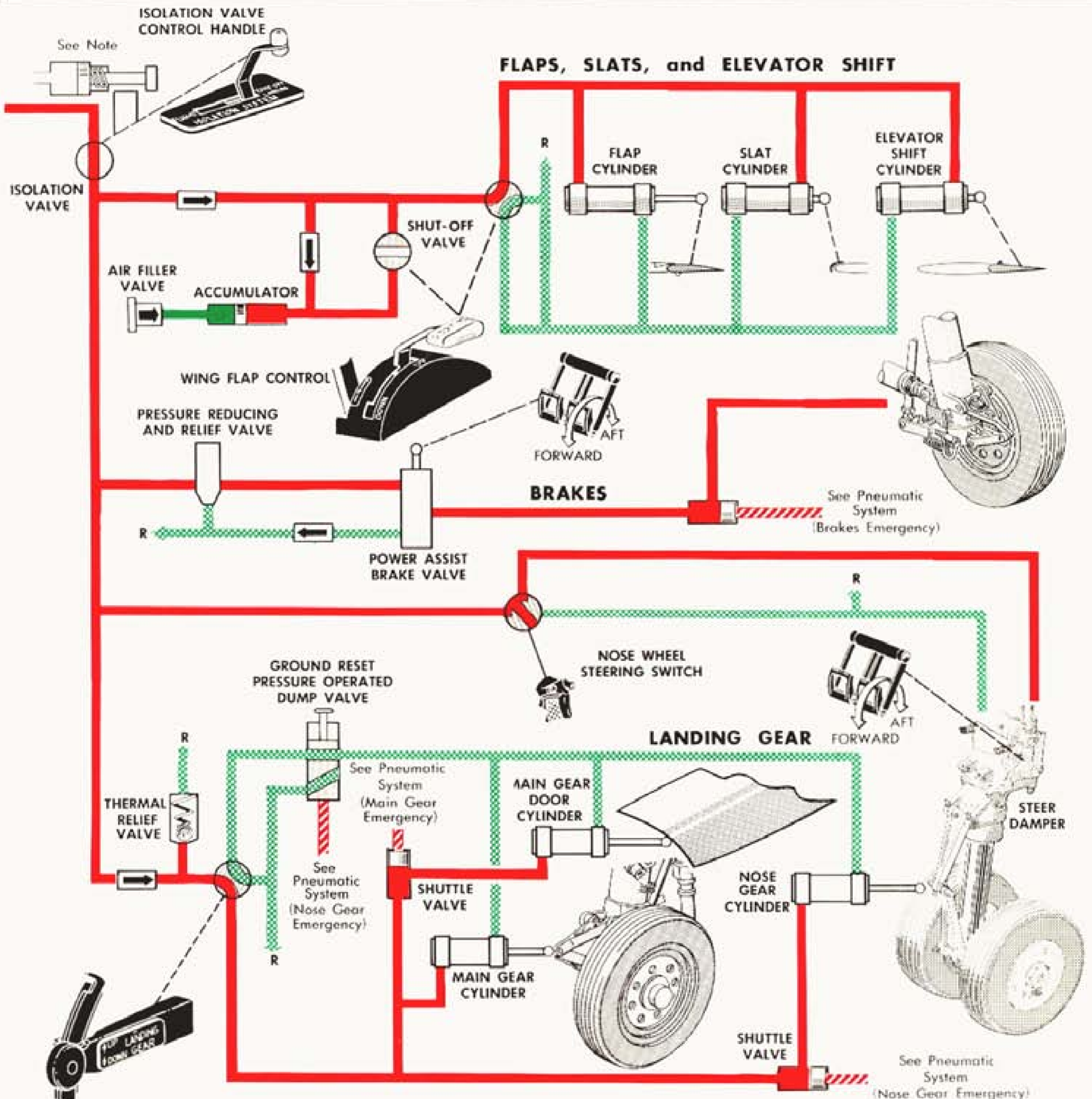











Figure 1-11. Hydraulic Power Supply System—Schematic (Sheet 1)





LANDING GEAR CONTROL HANDLE

*Code*

- |   |                 |   |                      |
|---|-----------------|---|----------------------|
|  | PRESSURIZED AIR |  | EMERGENCY AIR        |
|  | PUMP SUCTION    |  | RETURN               |
|  | PRESSURE        |  | MECHANICAL ACTUATION |
|  | STATIC          |  | ELECTRICAL ACTUATION |
|  | SELECTOR VALVE  |  | CHECK VALVE          |

*Note*

SEE FLIGHT HYDRAULIC SYSTEM SCHEMATIC FOR ISOLATION VALVE LOCK CYLINDER

Figure 1-11. Hydraulic Power Supply System—Schematic (Sheet 2)

# FLIGHT HYDRAULIC SYSTEM SCHEMATIC

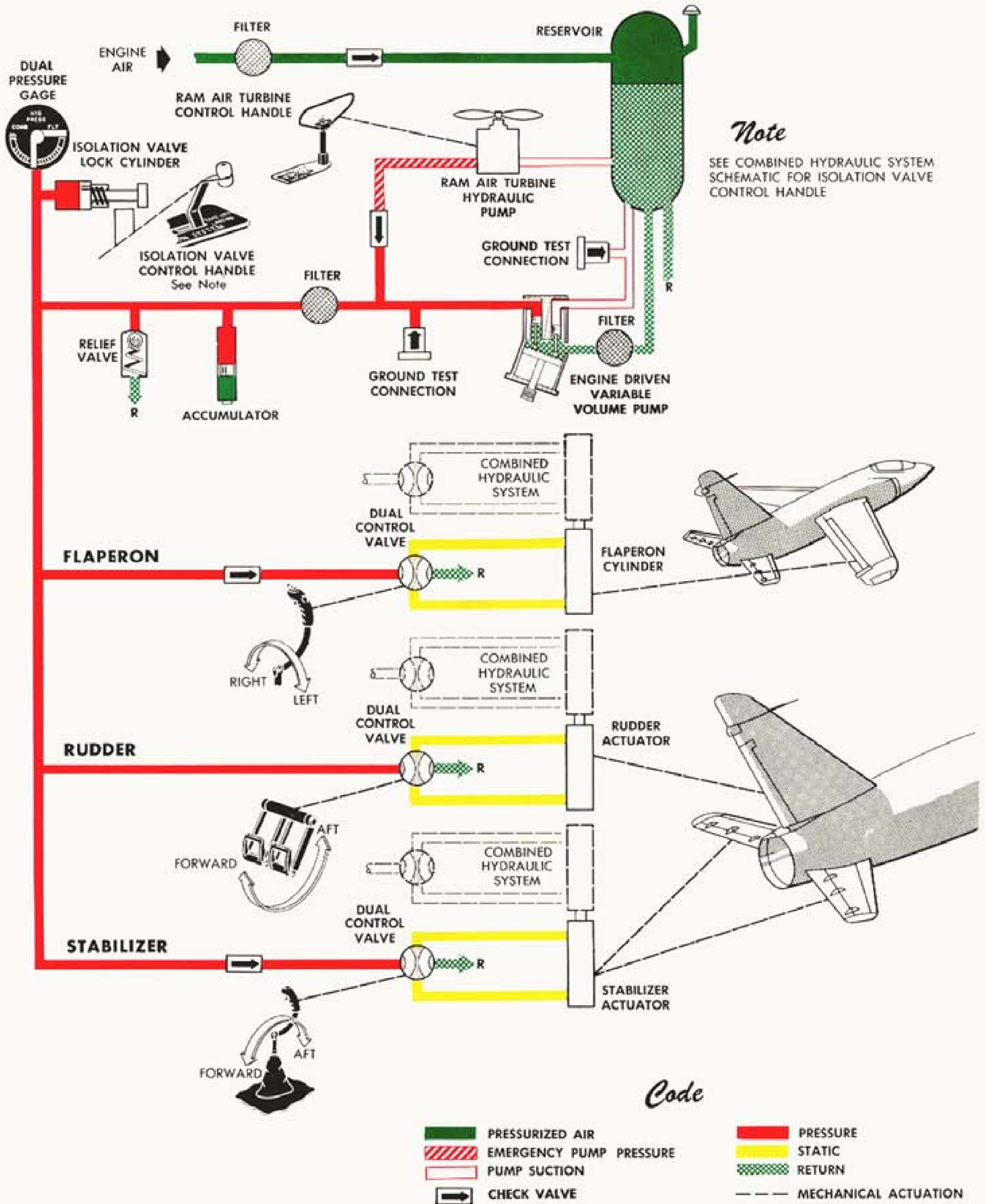

Figure 1-11. Hydraulic Power Supply System—Schematic (Sheet 3)

The flight system is also provided with a ram air emergency hydraulic power supply (air turbine driven hydraulic pump), for use if both the combined and flight systems fail. If the engine fails, but both normal systems are intact, and the engine is windmilling at a rate sufficient to permit the developed hydraulic pump pressure (as indicated by the flight system hydraulic pressure gage) and flow to operate the control surfaces, use of the ram air power supply is not required. However, if either the flight hydraulic system or the combined hydraulic system fails, the ram air turbine should be extended for the approach configuration of the airplane. Extension prior to the approach will be at the discretion of the pilot.

The rudder, stabilizer, and flaperon actuators are dual type cylinders. They are controlled by valves installed directly on the actuators and mechanically connected to the pilot's controls. Each valve controls the cylinder section of the dual type actuator on which it is installed. See figure 1-16 for hydraulic fluid specifications and figure 1-11, for a schematic diagram of the systems.

#### NORMAL CONTROLS AND INDICATORS.

#### HYDRAULIC SYSTEM ISOLATION CONTROL LEVER.

This control lever (9, figure 1-6), is located outboard of the right console. The lever is moved inboard to release, then forward to FLIGHT or aft to TAKE-OFF LANDING. In FLIGHT position, only the rudder, stabilizer, flaperons, speed brakes, arresting hook and tail skid are hydraulically operable. In the TAKE-OFF LANDING position, all units are operable. A spring loaded lock cylinder, operated by pressure from the flight system, prevents return of the isolation system lever to TAKE-OFF LANDING if the flight system pressure drops below operable pressure (400 to 800 psi).

#### Note

The actuators essential to flight (rudder, stabilizer and flaperon) are powered simultaneously by both of the hydraulic systems regardless of the position of the isolation system lever.

#### HYDRAULIC PRESSURE GAGES.

On some airplanes,<sup>1</sup> separate flight and combined system hydraulic pressure gages (30 and 25, figure 1-5) are installed on the instrument panel. The dials show hydraulic system pressure in psi and are numbered from 0 to 5000. The normal reading should be 3000 psi. Pressure indication may momentarily drop when a system or systems are being operated. On later airplanes,<sup>2</sup> a dual pressure gage (32, figure 1-5A) is provided on the instrument panel. This dual pressure gage does not show hydraulic system pressures in psi but has two arcs (one for the combined system and one for the flight system) which are each divided into three segments. The upper segments indicate normal pressures, the center

segments indicate safe pressures and the lower segments indicate unsafe pressures.

#### Note

When in operation, the pressure developed by the ram air power supply will be indicated on the flight system gage.

#### RAM AIR (EMERGENCY) POWER SUPPLY SYSTEM.

A ram air powered hydraulic system supply is provided to furnish hydraulic pressure to the units essential to flight (flaperons, stabilizer and rudder actuators) when the engine driven pumps are inoperative. The system consists primarily of an air turbine driven hydraulic pump installed on the inner side of a door which opens into the airstream. The door is located on the underside of the fuselage aft of the forward speed brake and is hinged on the right side. When the latch on the left side is released, the door drops open and exposes the air turbine to ram air, which drives the turbine and, in turn, the hydraulic pump. Fluid for this system is supplied from the flight system reservoir. Pressure is indicated on the flight system gage and will be approximately 2900 psi at 200 knots IAS, approximately 1000 psi at 120 knots IAS and approximately 500 psi at 100 knots IAS. As airspeed decreases, the hydraulic pressure required for control surface movement also decreases.

#### Note

If no combined system hydraulic pressure exists, the forward speed brake retracts automatically by means of a retraction spring and impact air pressure, and the aft brakes trail when the ram air turbine is extended. Therefore, the forward speed brake will not interfere with air turbine operation. An electrical interlock on the turbine door automatically selects speed brakes up when the turbine is extended to assist retraction should any pressure be available.

The air turbine should be extended only under one of the following conditions:

- a. Engine seizure.
- b. If either the power control hydraulic system or the combined hydraulic system fails, the ram air turbine should be extended for the approach configuration of the airplane. Extension prior to the approach will be at the discretion of the pilot.

#### EMERGENCY HYDRAULIC TURBINE CONTROL HANDLE.

The emergency hydraulic turbine control handle (6, figure 1-4; or 6, figure 1-4A) is located on the outboard side of the left console and is PULLED INBOARD, THEN UP, to release the air turbine door.

When the handle extends to the detent, the turbine will extend and lock. When the handle is pulled, it releases the latch, allowing the door with its attached

<sup>1</sup> Airplanes BuNo. 138610a through 138645b.

<sup>2</sup> Airplanes BuNo. 141728c and subsequent.

air turbine and hydraulic pump to fall open by spring and gravity. When the door reaches full out, an automatic lock secures it.

#### Note

The air turbine cannot be retracted by the pilot while in flight but must be stowed by ground personnel.

## PNEUMATIC POWER SUPPLY SYSTEM.

This system (figure 1-12) provides compressed air for in-flight charging of the pneumatic system air bottles used for normal operation of the canopy, gun feeders, gun charging and gun compartment ventilation doors, and for emergency operation of the wheel brakes, landing gear and canopy jettisoning. These systems are equipped with air storage bottles and control valves. The pneumatic power supply system consists primarily of a d-c motor driven air compressor which maintains a charge of air in the various systems air storage bottles. The compressor is supplied inlet air from an engine air bleed line. A pressure switch responds to the same pressure as the pneumatic pressure gage (12, figure 1-6) which is located on the right console. The gage will only indicate the pressure in the system bottle which has the least pressure. The pressure switch controls the starting and stopping of the compressor motor at the following pressures:

Cut-out Pressures (pressure switch stops compressor)—

Minimum—2900 psi

Maximum—3100 psi

Cut-in Pressures (pressure switch starts compressor)—

Minimum—2600 psi

Maximum—200 psi below cut-out pressure. (This means that wherever in the tolerance range the cut-out point occurs, the pressure must drop at least 200 psi below that point before the compressor cuts in.)

An external connection in the left wheel well provides for ground charging of the systems air storage bottles prior to flight to enable immediate use of the various systems. Electrical power for the compressor motor is supplied from the primary d-c bus through a 80 ampere fuse in the wheel well junction box. This electrical power is directed through a relay. The relay control circuit is supplied from the monitored d-c bus, which is powered only when the generator is operative. Therefore, the compressor will not operate when the airplane is on battery power alone. The relay control circuit is also protected by a circuit breaker.

## CANOPY PNEUMATIC SYSTEM.

The canopy is operated by a cylinder which is actuated by pressure from the pneumatic system. Air pressure for normal operation is stored in a 50 cubic inch bottle, maintained in readiness by the pneumatic power supply system. The air pressure supply for emergency operation is derived from either the 30 cubic inch emergency wheel

brake bottle or the normal canopy bottle, whichever has the higher pressure and is routed through the emergency control valve to by-pass the normal pressure reducer valve and normal selector valve.

## FLIGHT CONTROL SYSTEM.

The flight control surfaces consist of flaperons and slats on the wings, a movable stabilizer-elevator and a rudder. The flaperons, stabilizer-elevator and rudder are operated hydraulically by a conventional control stick and rudder pedal installation. Normally, these three surfaces are powered by the combined and flight hydraulic systems, but in case of engine failure and if the windmilling engine does not produce sufficient pressure, they may be powered by the ram air turbine in the flight system. Artificial feel and electrically operated trim are included in these control systems. The remainder of the surfaces, (flaps, slats, speed brakes) are hydraulically powered by the combined hydraulic system. Additional directional stability is provided by a directional stability control system.

### LATERAL CONTROL SYSTEM (FLAPERONS).

The lateral control system (figure 1-13) consists of a movable flaperon on each wing, an electrical trim system and an artificial feel system.

Lateral movement of the control stick directs hydraulic pressure from the combined and flight hydraulic power systems to raise and lower the flaperons through an arc of 0-55 degrees with the flaps up and 6-55 degrees with the flaps down.

To prevent excessive blow-back at high dynamic pressures, a biasing cylinder, working in conjunction with and fed by pressure from the main actuator, is installed to add additional flaperon hinge moment.

#### Note

Each flaperon is raised to approximately 6 degrees up neutral position when the flaps are lowered. This 6 degree pop-up is accomplished in the first 7 degrees of the flap extension.

Contoured stick stops in the lateral control system prohibit excessive lateral stick motion at large forward stick displacements; a combination that could produce excessive sideslip angle build-up in high-rate rolls as a result of inertial cross-coupling. These stops can be readily felt on the ground—with the stick fully displaced laterally, it will be forced inboard by the stops as it is moved forward. Under normal flight conditions, the stops are never encountered.

The contoured stop installation precludes roll divergence under all subsonic flight conditions. At supersonic speeds, intentional forward stick motion is prohibited in abrupt, large displacement rolls pending further flight investigation. See Maneuvers paragraph, Section V.

Normally, both hydraulic systems work simultaneously

# PNEUMATIC SYSTEM SCHEMATIC

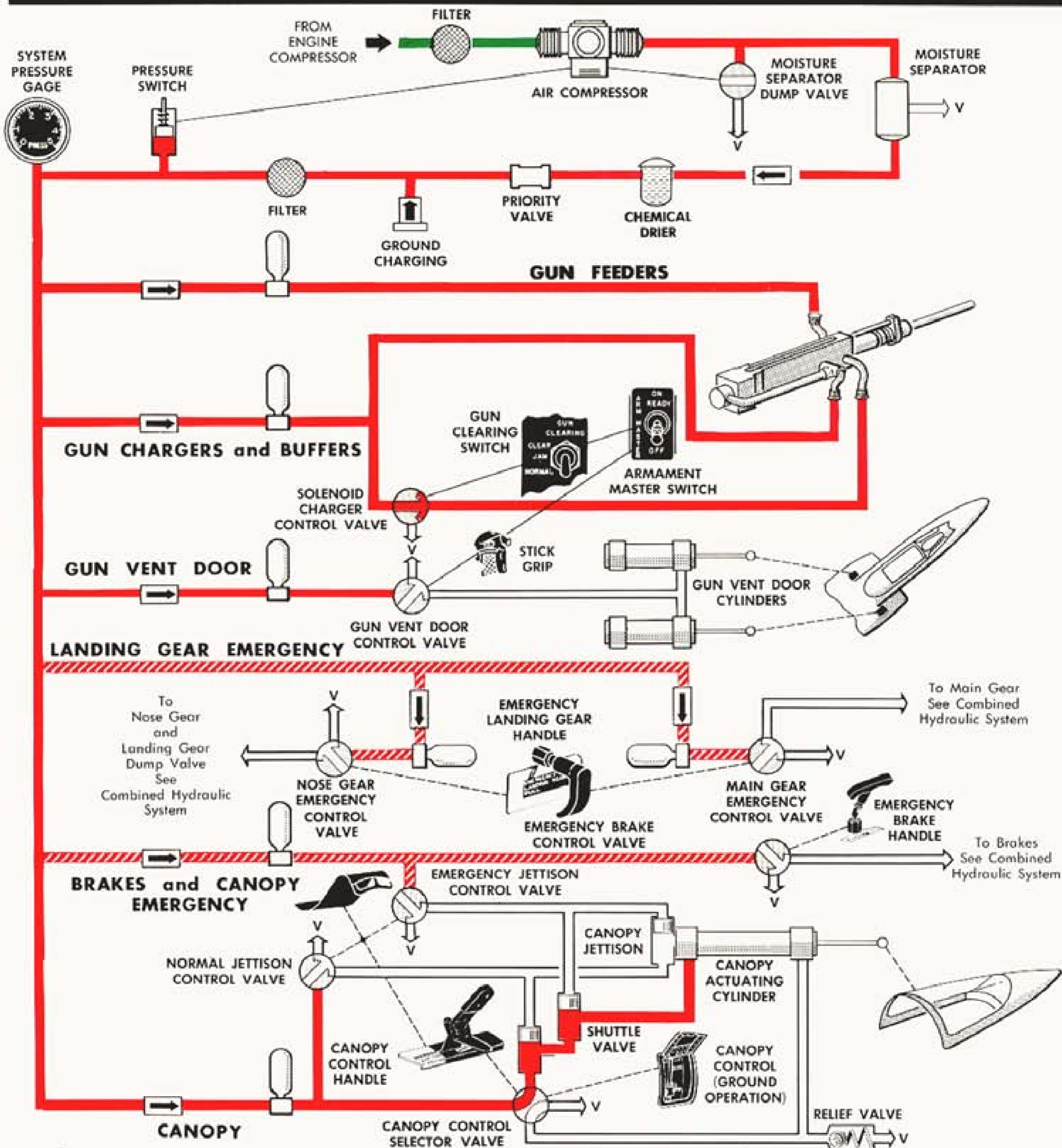

**Code**

- PRESSURIZED AIR
- PRESSURE
- EMERGENCY AIR
- VENT (V)
- MECHANICAL ACTUATION
- ELECTRICAL ACTUATION
- CHECK VALVE
- AIR BOTTLE

**Note**

BRAKES, CANOPY and GUN SYSTEMS ARE PRESSURE REDUCED TO SYSTEM REQUIREMENTS

EMERGENCY OPERATION OF CANOPY IS BASED UPON 3000 PSI PRESSURE EXHAUSTING CANOPY "CLOSED" PRESSURE THROUGH PRESSURE RELIEF VALVE IN CANOPY "CLOSED" LINE.

Figure 1-12. Pneumatic System—Schematic

to operate the lateral control system. However, either hydraulic system alone will give satisfactory control at all airspeeds.

#### LATERAL ARTIFICIAL FEEL SYSTEM.

Since hydraulic operation of the flaperons prevents air load feed-back to the control stick, an artificial feel system is installed to simulate the effect. The system consists of a cam and spring loaded follower installed in the forward section of the fuselage. Movement of the cam against the follower roller induces a force in the control system that opposes stick movement. This force is dependent on control stick position only.

#### LATERAL TRIM CONTROL SYSTEM.

An electrical actuator varies the neutral position of the artificial feel system, thereby varying the neutral stick position which in turn, establishes lateral trim. The action of the electrical actuator does not affect the relative motion between the stick and flaperons.

#### LATERAL TRIM CONTROL SWITCH.

The actuator is controlled by the four way trim control thumb switch (9, figure 1-7) on the control stick grip which is also used for longitudinal trim control. Changes in stick force resulting from operation of the trim actuator can be easily overpowered; however, a circuit breaker is provided to deenergize the actuator in case of malfunction in the electrical circuits.

#### LATERAL TRIM POSITION INDICATOR.

The lateral trim position indicator (11, figure 1-7) consists of a calibrated plate mounted on the knuckle of the control stick and is entirely mechanical in operation. The plate is calibrated from zero to three to indicate left or right trim. An index line on the stick moves along the edge of the calibrated plate to indicate the amount of lateral trim.

#### Note

The values on the plate do not indicate actual degrees of trim.

#### LONGITUDINAL CONTROL SYSTEM.

The longitudinal control system (figure 1-14) consists of a hydraulic pressure operated, all movable horizontal stabilizer and geared elevator, with an elevator shift mechanism, an electrical trim system, and an artificial feel system. Longitudinal control is provided by a hydraulic pressure operated, all movable horizontal stabilizer. Fore and aft movement of the control stick directs a valve to let hydraulic pressure from the combined and flight hydraulic power systems move the stabilizer accordingly. Like the flaperon system, the stabilizer is normally controlled simultaneously by both the combined and flight hydraulic systems, but either hydraulic system alone can control the stabilizer at any airspeed, and the ram air turbine can be used if engine failure results in insufficient hydraulic pressure.

The elevator is automatically locked in line with the stabilizer when the wing flap control handle is set to UP, and the two units move as a single control surface. When the wing flap control handle is set to DOWN the elevator is geared to stabilizer motion so that when the stabilizer leading edge is 5 degrees up, the elevator forms an angle of zero degrees with the stabilizer chord center line; and when the stabilizer leading edge is 18 degrees down, the elevator forms an angle of 27 degrees up with the stabilizer chord center line. The change in elevator control from locked to geared is accomplished automatically by an elevator shift cylinder which is actuated by hydraulic pressure from the flap selector valve. Since the elevator is controlled only by stabilizer motion, there is no independent elevator control.

#### LONGITUDINAL ARTIFICIAL FEEL SYSTEM.

Since the hydraulic operation of the stabilizer prevents air load feed-back to the control stick, an artificial feel system is installed to simulate the effect. The system consists of a cam and spring-loaded follower installed in the aft end of the fuselage. Movement of the cam against the follower induces a force in the control system that opposes stick movement. This force is dependent on control stick position only.

Other items that contribute to the pilot's feel of the airplane are the positive and negative bobweights installed at the control stick and at the aft end of the fuselage and the Eddy Current Damper installed forward of the control stick. The latter, being anchored to the floor and through a link attached to the stick, will produce stick forces as a function of stick velocity.

#### LONGITUDINAL TRIM CONTROL.

The electrical trim actuator varies the neutral position of the artificial feel system, thereby varying the neutral stick position, which in turn establishes longitudinal trim. The action of the electrical actuator does not affect the relative motion between the stick and the stabilizer. The actuator is controlled by the four way trim control thumb switch (9, figure 1-7) on the control stick grip, which is also used for lateral trim. Changes in stick force resulting from operation of the trim actuator can be easily overpowered; however, a circuit breaker is provided to deenergize the actuator in case of malfunction in the circuits.

#### LONGITUDINAL TRIM (STABILIZER) POSITION INDICATOR.

The longitudinal trim position indicator (15, figure 1-5; or 16, figure 1-5A) is mounted on the instrument panel. The dial face is calibrated in degrees of stabilizer position over the trim range available. Nose-up indications mean airplane nose-up and not stabilizer nose-up. A separate circuit breaker is provided for the indicator circuit.

#### SLATS, FLAPS AND ELEVATORS LOCKED INDICATOR.

This barber pole indicator (44, figure 1-5; or 44, figure 1-5A) is mounted on the instrument panel. The in-

# LATERAL CONTROL SYSTEM — SCHEMATIC

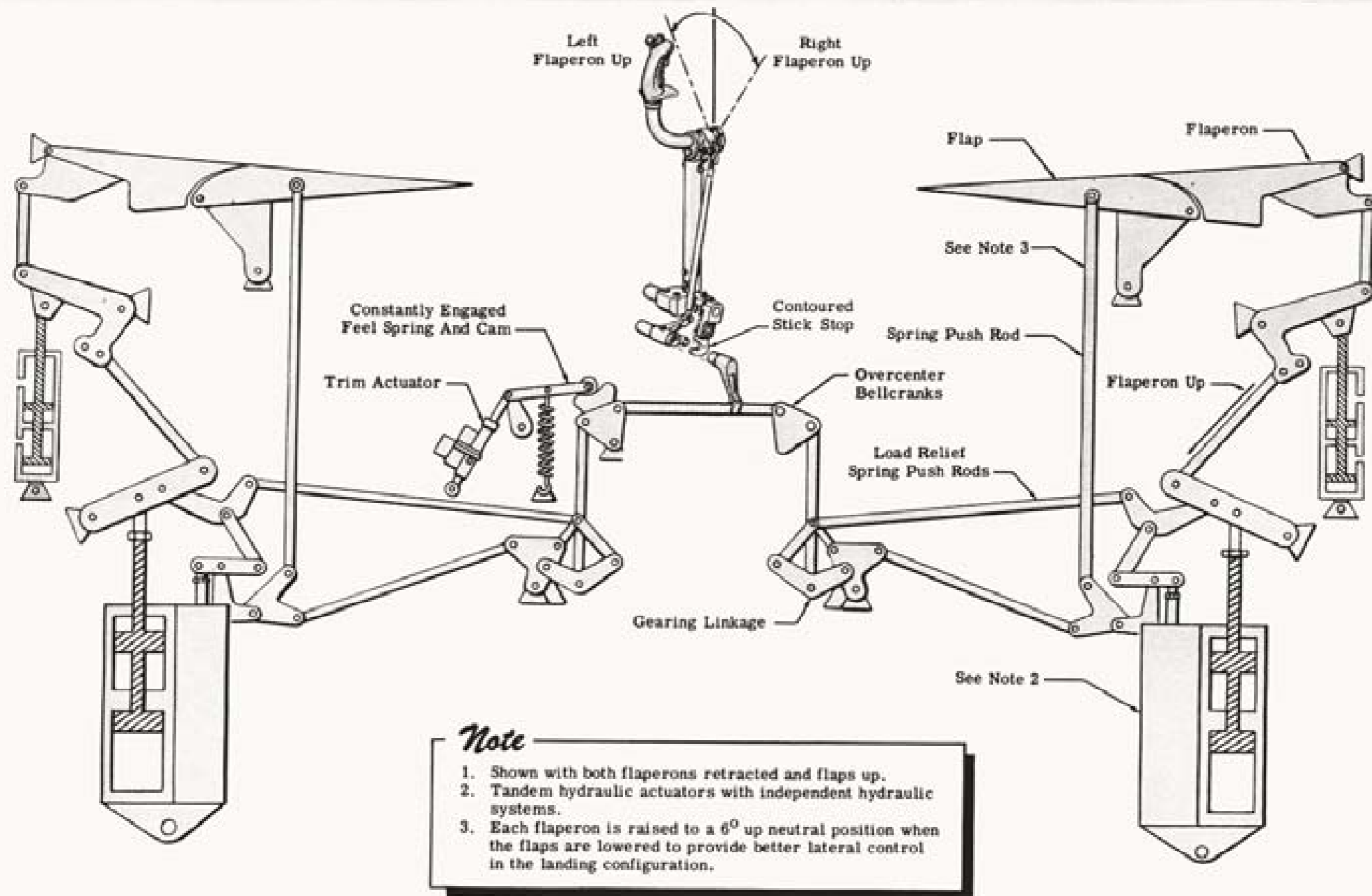

NAVWEP5 01-85FCG-501

Section 1

Figure 1-13. Lateral Control System—Schematic

# LONGITUDINAL CONTROL SYSTEM — SCHEMATIC

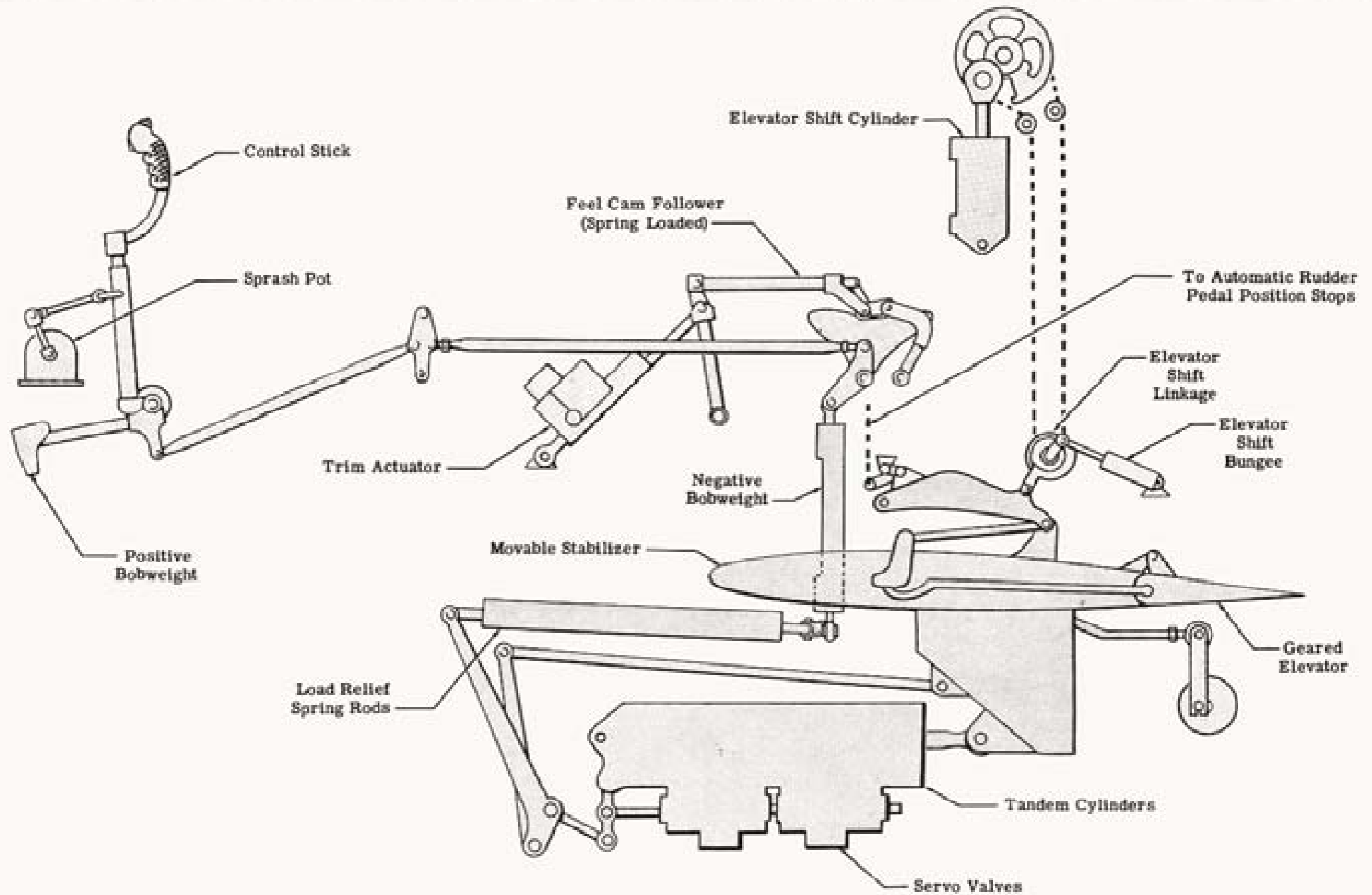

Figure 1-14. Longitudinal Control System—Schematic



indicator reads YES, provided the slats and flaps are locked up and the elevators are locked in the zero angle position with reference to the stabilizer. The indicator reads NO when elevators are in geared position which occurs when the flap handle is in the down position. A barber pole indication results when neither of the above conditions is met or power is off.

## WARNING

Barber pole or NO readings indicate an unsafe condition for high speed flight (270 knots IAS and above). Land as soon as practicable.

### RUDDER CONTROL SYSTEM.

Movement of the rudder pedals directs a valve to let hydraulic pressure from the combined and flight hydraulic power systems move the rudder accordingly. Like the flaperon and stabilizer systems, the rudder is normally controlled by both the combined and flight hydraulic systems, but either hydraulic system alone will give satisfactory control at all airspeeds. See figure 1-15. Automatic rudder pedal position stops (actuated by the elevator shifting mechanism), limits rudder travel to 5 degrees each side of neutral with flaps UP and to 22 degrees each side of neutral with flaps down. This insures that abrupt pedal movements will not impose excessive vertical fin loads which could cause structural failure.

### RUDDER PEDALS ADJUSTMENT HANDLE.

The rudder pedals are adjusted by raising the rudder pedals adjustment handle (36, figure 1-5; or 38, figure 1-5A), which extends into the cockpit between the pedal hangers and then moving the pedals to the desired position. To lock the pedals in the selected position, lower the handle until a notch engages the bolt in the adjustment fitting.

### DIRECTIONAL ARTIFICIAL FEEL.

Since hydraulic operation of the rudder prevents air load feed-back to the pedals, an artificial feel system is installed to simulate effect. The system consists of a cam and spring loaded follower installed in the aft end of the fuselage under the fin. Movement of the cam against the follower induces a force in control system that opposes pedal movement. This force is dependent on pedal position only.

### DIRECTIONAL STABILITY CONTROL SYSTEM.

The function of the directional stability control system is to provide additional directional stability. The system comprises a directional controller amplifier, a control actuator, a trim control unit and a trim control on-off switch.

The directional controller amplifier contains a yaw rate gyro and the circuitry necessary to provide correction signals for the directional controller actuator. Signals produced by the yaw rate gyro are proportional to the

yawing rate of the airplane. These signals are fed to the directional controller actuator which is mechanically linked to the rudder actuator control valves. Thus, uncoordinated airplane motions about the yaw axis automatically produce corrective rudder position. The movement of the control valve linkage due to directional controller actuator operation is not fed back to the rudder pedals. The pilot may override the system and perform an uncoordinated maneuver such as a side slip by exerting a normal amount of rudder pressure.

The system requires both d-c and three phase a-c power for operation. D-c power is obtained from the secondary d-c bus through a circuit breaker on the lower circuit breaker panel in the cockpit. The yaw damper (directional stability) and trim control ON-OFF switch controls the d-c power to the directional controller amplifier. The three phase ac from the a-c instrument bus is routed directly to the directional controller amplifier through a pair of one ampere circuit breakers.

### YAW DAMPER (DIRECTIONAL STABILITY) AND RUDDER TRIM SWITCH.

This ON-OFF switch (24, figure 1-4; or 26, figure 1-4A) is used to control d-c power to the directional controller actuator. When this switch is set to OFF and the d-c power switch is set to BAT. & GEN. or BAT. ONLY, the directional stability and trim system receive only a-c power and are in a stand-by condition. When the switch is set to ON, d-c power is supplied to the directional controller actuator and both the directional stability and directional trim systems are placed in operation.

### DIRECTIONAL TRIM CONTROL SYSTEM.

This system enables the pilot to manually trim the rudder to a new neutral position to offset any directional out-of-trim condition. Rudder movements produced by the pilot or the directional stability system are made from this neutral position. Rudder pedals, however, remain in a neutral position regardless of the rudder trim position. Four and one-half degrees of rudder trim are available on either side of neutral.

### DIRECTIONAL TRIM CONTROL KNOB.

The directional trim control knob (27, figure 1-4; or 27, figure 1-4A) enables the pilot to manually select rudder trim by controlling the neutral length of the directional controller actuator. This actuator, in turn, operates the rudder actuator control valves to move the rudder to the selected trim position. Rotating the directional trim control knob to the left from zero produces left rudder trim and rotating the knob to the right from zero produces right rudder trim.

## WING FLAPS.

### WING FLAPS CONTROL SYSTEM.

Movement of the flaps control handle directs combined hydraulic system pressure to the flaps actuating cylinders when the hydraulic system isolation valve is positioned for landing and take-off operations.

# RUDDER CONTROL SYSTEM — SCHEMATIC

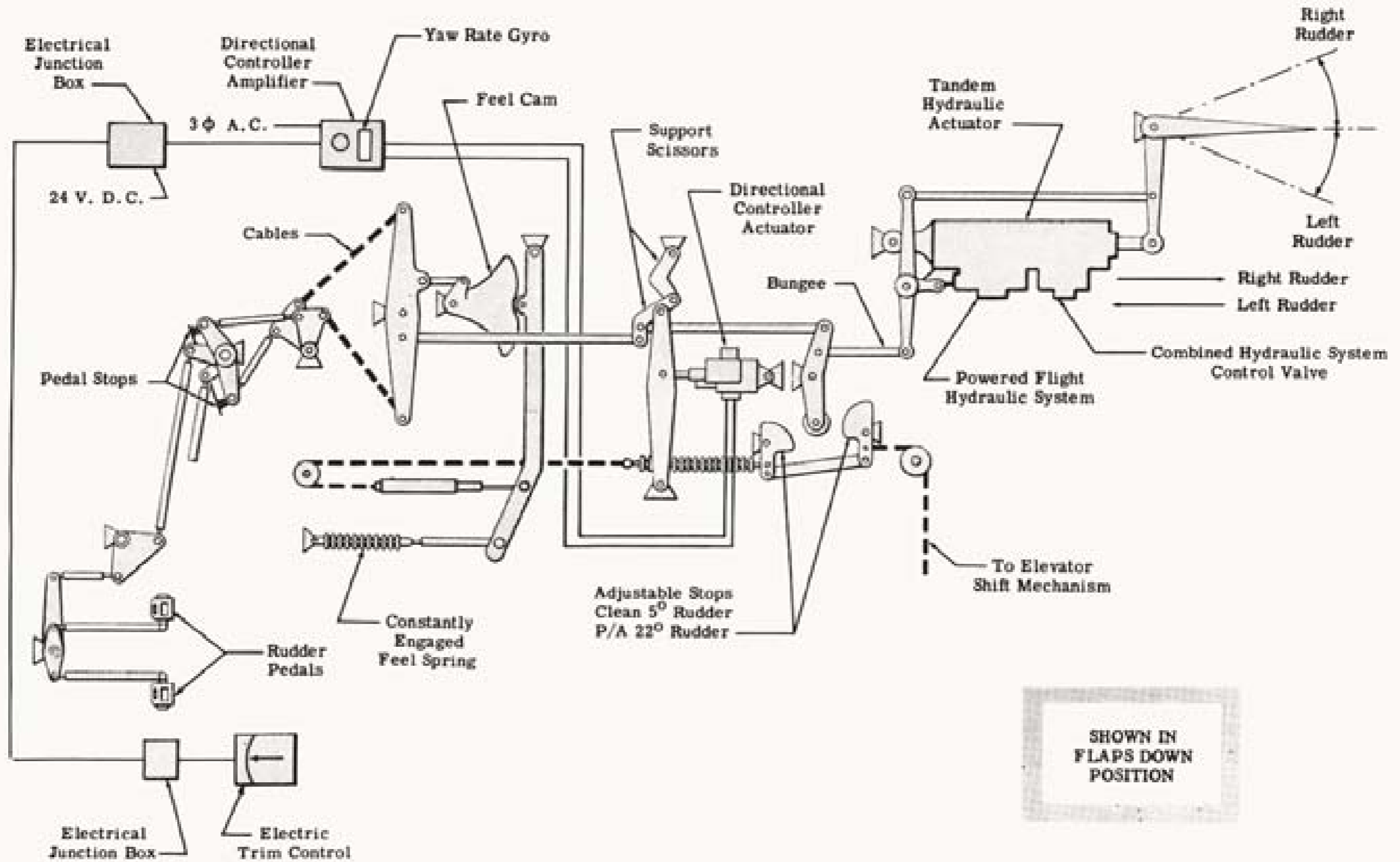

Figure 1-15. Rudder Control System—Schematic

## FLAPS CONTROL HANDLE.

The flaps control handle (22, figure 1-4; or 11, figure 1-4A) is located in the control quadrant on the left console and has two detented positions. The handle must be moved inboard to clear the detents before it can be moved fore and aft. With the handle at UP, the flaps are fully retracted. When the handle is moved to DOWN, the flaps are fully extended.

## WING FLAPS EMERGENCY SYSTEM.

The flaps hydraulic system contains an accumulator which permits one extension of the flaps, slats, and unlocking of the elevator after a hydraulic failure.

### Note

If the flaps control handle is inadvertently moved to UP after the flaps are extended by the accumulator, the flaps will blow up but the elevator will remain unlocked.

## WHEELS AND FLAPS POSITION INDICATOR.

The electrically operated wheels and flaps position indicator (51, figure 1-5; or 53, figure 1-5A) is mounted on the left auxiliary instrument panel. The position of the flap at the top of the indicator corresponds to the actual flap position whenever both flaps are either UP or DOWN. During transit between the UP and DOWN flap positions, the pointer of the indicator will move out of sight.

## SLATS.

### SLATS CONTROL SYSTEM.

The slats are hydraulically actuated by combined hydraulic system pressure routed through the flaps selector valve. When the flaps are raised, the slats retract; and when the flaps are lowered, the slats extend.

## ANGLE OF ATTACK— STALL WARNING SYSTEM.

The angle of attack-stall warning system consists primarily of a detector unit, an indicator, a rudder pedal shaker unit, a cockpit light assembly and a wing approach light assembly.<sup>1</sup> Angle of attack is the angular relationship (about the pitch axis) between a fore and aft reference line (such as the fuselage reference line) and the flight path.

### STALL WARNING.

The detector unit senses angle of attack by the effect of airflow on a probe which is located on the left<sup>2</sup> or right<sup>1</sup> side of the nose and, by use of a potentiometer circuit, transmits signals to the indicator unit. The

indicator interprets the signals from the detector and provides continuous angle of attack indications on the dial of the unit.

### Note

Since the angle of attack indicator was designed for low speed approaches, it will not provide accurate angle of attack reference above .6 true mach number.

When the angle of attack airflow approaches a stall condition, a switch in the indicator closes and completes a ground circuit in the rudder pedal shaker circuit, causing the shaker to vibrate the rudder pedal and physically alert the pilot to the impending stall condition. The rudder pedal shaker unit can operate, however, only when the wing flaps are down, since the shaker motor power circuit is completed through a switch closed when the wing flap control handle is in the DOWN position.

### Note

An artificial stall warning indication of 22 on the angle of attack indicator has been selected as that which represents approximately 14% above stall speed. This was selected as a minimum airspeed at which recovery from approach to stall could be made with a minimum loss of altitude.

### APPROACH.

The cockpit angle of attack light assembly (8, figure 1-5A) consists of three lights, arranged vertically and covered by a cap. Over the upper light, an arrowhead on the cap points downward, while a similar arrowhead over the bottom light points upward. As a result of signals from the detector, the indicator unit switches function to light the top light for a high angle of attack, the center light for a medium angle or the bottom light for a low angle. Light overlap occurs on either side of the center light, causing the center light and the top or bottom light to glow together for a slightly high or low angle of attack. The arrowheads over the lights point to the direction for the nose to go to correct for the condition represented.

On some airplanes,<sup>3</sup> the cockpit angle of attack light assembly indicates at all times. On other airplanes,<sup>4</sup> the cockpit angle of attack lights will function only when the landing gear is down. When the cockpit instrument lights are on, a cockpit angle of attack light relay is energized, resulting in the insertion of a dimming resistor into each light circuit. All lights in the angle of attack-stall warning system are powered by the secondary d-c bus through the exterior lights "B" circuit breaker.

The remainder of the system, including the rudder pedal

<sup>1</sup>Airplanes BuNo. 141728c and subsequent.

<sup>2</sup>Airplanes BuNo. 138610a through 138645b.

<sup>3</sup>Airplanes BuNo. 138610a through 141750c.

<sup>4</sup>Airplanes BuNo. 141751d and subsequent.

shaker unit, is also powered by the secondary bus through the angle of attack circuit breaker. Absence of power to the system is shown by OFF appearing on the dial face of the indicator. After landing, rudder pedal shaker operation is prevented by interruption of the power circuits through the No. 1 ground indication relay.

### ANGLE OF ATTACK INDICATOR.

The angle of attack indicator (7, figure 1-5A) is located on the instrument panel. It interprets the signals from the detector and provides continuous angle of attack indications on the dial of the unit.

#### Note

Since the angle of attack indicator was designed for low speed approaches, it will not provide accurate angle of attack reference above .6 true mach number.

### COCKPIT ANGLE OF ATTACK LIGHT ASSEMBLY.

See Angle of Attack—Stall Warning System paragraph, this section.

## SPEED BRAKES.

### SPEED BRAKES CONTROL SYSTEM.

The speed brakes (one forward and two aft) are controlled by a switch which positions two solenoids that operate a hydraulic selector valve, which in turn, routes hydraulic pressure from the combined hydraulic power system to the speed brake actuating cylinders.

### SPEED BRAKES SWITCH.

The three position speed brakes switch (9, figure 1-4; or 10, figure 1-4A) is located on the power control lever. The switch is spring loaded to a center (off) position which holds the brakes at any selected angle. The UP position fully retracts the speed brakes. The DOWN position is used to obtain any required degree of extension by holding the switch at this position, then releasing it when the brakes reach the desired angle.

### CAUTION

The airplane should not be landed with the speed brakes extended, as the aft brakes will strike the deck and be damaged.

### SPEED BRAKES OVERRIDE SWITCH.

The two position guarded speed brakes override switch (28, figure 1-4; or 7, figure 1-4A), located on the left console, can be set to NORM.,<sup>1</sup> NORMAL<sup>2</sup> or SPEED BRAKES OVERRIDE.

### OPERATION.

- In the event of electrical failure, the speed brakes will automatically retract.
- Speed brakes override switch set at NORM—

When the landing gear is down the speed brakes cannot be extended. When the landing gear is up and the speed brakes are down, extending the landing gear will automatically retract the brakes, and they cannot be extended until the landing gear is retracted.

c. Speed brakes override switch set at SPEED BRAKES OVERRIDE—The speed brakes can be extended and retracted regardless of the position of the landing gear.

d. If the combined hydraulic system fails in flight and the speed brakes are down, the speed brakes switch to UP will cause the forward speed brake to retract and the two aft brakes to trail, regardless of the position of the speed brakes override switch.

### SPEED BRAKES POSITION INDICATOR.

This barber pole indicator (43, figure 1-5; or 43, figure 1-5A) is mounted on the instrument panel. When all three brakes are at least partly extended, the indicator reads OUT. When all three brakes are fully retracted, it reads IN. In the event of an electrical failure, a barber pole appears on the indicator.

## LANDING GEAR SYSTEM.

The landing gear is of the tricycle type, consisting of two main gear wheels and a steerable, dual-wheel nose gear. In addition, a tail skid extends and retracts simultaneously with the landing gear. Normal power for the landing gear is supplied by the combined hydraulic system. Emergency operation of the landing gear is provided by a pneumatic power supply system. A solenoid operated latch is installed to prevent inadvertent gear retraction while the weight of the airplane is on the wheels.

### NORMAL CONTROLS.

#### LANDING GEAR CONTROL LEVER.

This two position lever (53 figure 1-5; or 52, figure 1-5A) is located on the auxiliary instrument panel over the left console. When the lever is moved to DOWN (after moving inboard to release from detent), hydraulic cylinders open the wheel doors, lower and lock down the main and nose gears. When the lever is moved to UP (after inboard movement to release), the main and nose gears retract and the main and nose wheel doors close. A solenoid operated latch is installed to prevent inadvertent gear retraction when the airplane is on the deck. When airborne, the struts extend, releasing the latch and permitting the gear to be retracted. Extension or retraction of the landing gear may be accomplished with the normal control only when the isolation system lever is in the TAKE-OFF LANDING position.

#### Note

When the landing gear is extended, the speed brakes (if extended) are automatically retracted (provided the speed brakes override

<sup>1</sup> Airplanes BuNo. 138610a through 138645b.

<sup>2</sup> Airplanes BuNo. 141728c and Subsequent.

switch is set at NORM.) to clear the deck upon landing. (See Speed Brakes Control System in this section.)

#### NOSE WHEEL STEERING SWITCH.

The nose wheel steering switch (12, figure 1-7) is a push button switch located on the control stick grip.

#### EMERGENCY CONTROLS.

##### LANDING GEAR EMERGENCY CONTROL HANDLE.

This handle (50, figure 1-5; or 54, figure 1-5A) is located on the left auxiliary instrument panel and, when pulled out, actuates a cable to open air bottles and direct air pressure to the cylinders to open the doors, lower and lock the nose landing gear, and permit extension and locking of the main landing gear through action of the shrink cylinders and gravity. The handle is provided with a detent to hold it out and insure air pressure supply to complete the extension of the gear.

#### CAUTION

Airspeed must be reduced to 180 knots IAS before using emergency control.

Once the emergency control has been used, the gear cannot be retracted until normal operation has been restored by servicing the system.

#### Note

The landing gear warning light remains on if the landing gear control handle is at UP. Moving the control handle to DOWN will extinguish the light, power the secondary bus and permit gear down indication if the gear goes down and locks.

##### LANDING GEAR CONTROL LEVER DOWN LOCK RELEASE KNOB.

A manually operated release knob (49, figure 1-5; or 55, figure 1-5A) is located forward of the instrument panel bulkhead on the left side. If electrical failure should make the down lock solenoid inoperative, pulling the knob inboard will clear the landing gear control lever linkage to allow movement of the lever to UP.

#### INDICATORS.

##### WHEELS AND FLAPS POSITION INDICATOR.

A standard indicator (51, figure 1-5; or 53, figure 1-5A), which shows wheels down and locked or wheels up and locked is located on the left auxiliary instrument panel. In the event of a landing gear malfunction, the indicator will show which wheel or combination of wheels is in an unsafe condition.

##### LANDING GEAR WARNING LIGHT.

A red landing gear warning light (48, figure 1-5; or 56,

figure 1-5A), located near the landing gear controls on the left auxiliary instrument panel, glows whenever one or more of the gears are unlocked. In normal operation, the light will glow while the gear is in transit and remain on until all locks are secure. In emergency operation, the light will glow if the normal control is at UP and emergency gear extension has been used. Should this light remain illuminated when airborne and all gears are up and locked, check the stores emergency release circuit breaker located on the lower circuit breaker panel on the right cockpit wall. If pushing the circuit breaker in fails to extinguish the light, an electrical malfunction is indicated.

##### WHEELS WARNING LIGHT.<sup>1</sup>

A wheels warning light (5, figure 1-5A), located on the main instrument panel, flashes whenever the flaps are down and the throttle is retarded but the landing gear is not down. The light illuminates the word WHEELS on the plastic panel.

##### TAIL SKID.

The tail skid is raised by a hydraulic cylinder which is controlled by an electrically operated solenoid valve. This valve is positioned by means of a switch actuated by the landing gear control lever. When the landing gear control lever is placed in the UP position, the valve is opened and the tail skid is raised. When the lever is in the DOWN position, the valve is closed by spring action and the skid is extended by a dashpot. An additional control is provided by a power control lever switch. When the power control lever is advanced to a setting of 95% rpm or greater, the tail skid raises. Retarding the power to less than 95% rpm will not lower the tail skid if the landing gear control lever is in the up position.

#### Note

In the event of an electrical failure in the solenoid valve circuit, the valve is closed by spring action and the tail skid will be extended.

#### BRAKE SYSTEM.

##### NORMAL CONTROLS.

The brake pedals operate power assist brake valves (mounted on the pedals) to control hydraulic pressure to the wheel brakes. The hydraulic pressure is supplied by the combined hydraulic system and is not available unless the isolation system lever is in the TAKE-OFF LANDING position. With no combined hydraulic pressure available, adequate braking may still be obtained by pilot effort.

##### EMERGENCY CONTROL.

The wheel brakes emergency control handle (5, figure 1-4; or 4, figure 1-4A) is located aft on the left console. When pulled up, it actuates a cable connected to a valve,

<sup>1</sup> Airplanes BuNo. 141728c and subsequent.

which opens to admit pneumatic pressure from an air bottle into the brake lines.

#### Note

Once the emergency handle is used, the brakes are set full on. Release can be effected by pushing the handle down. Only four satisfactory applications of the brakes by the emergency system may be expected before it becomes necessary to allow sufficient time for the air bottle to be recharged. Once the emergency system has been used, the brakes will not operate through the normal hydraulic system until the system has been serviced.

## ARRESTING HOOK.

### NORMAL CONTROLS.

#### ARRESTING HOOK DOWN CONTROL HANDLE.

This control handle (27, figure 1-5; or 29, figure 1-5A) is located on the right auxiliary instrument panel. When pulled, a cable unlatches the arresting hook and allows it to fall into position. Once operated, the hook must be stowed by the ground or deck crew.

### WARNING

By design, the tail hook is positioned with the hook forward when retracted and pivots aft to a down and locked position. When the airplane is on the runway, the arresting hook may not extend fully. If use of the arresting hook is anticipated for field arresting gear engagements, it is desirable to lower the arresting hook while airborne. If the hook is then raised to the stinger position, it will allow a normal landing but will be available for an arrestment if necessary.

When test operating the system, make sure that personnel are clear of the hook.

#### ARRESTING HOOK UP CONTROL SWITCH.

This push button switch (26, figure 1-5; or 28, figure 1-5A) is located on the right auxiliary instrument panel, adjacent to the arresting hook down control handle. When the button is pushed, a hydraulic cylinder raises the hook clear of the deck to the stinger position to permit taxiing forward of the barrier and arresting cables. It is also possible to raise the arresting hook to the stinger position in flight by momentarily depressing the arresting hook up control switch. To lower the hook from stinger position back down to trail, pull the arresting hook down control handle.

#### Note

The arresting hook up control switch will lift the hook only when the hook is in the down and locked position.

#### ARRESTING HOOK WARNING LIGHT.

A red warning light (24, figure 1-5; or 21, figure 1-5A) that illuminates the words ARREST HOOK is located on the right auxiliary instrument panel and glows when the hook is in any intermediate position between retracted and full down and locked. The light also glows when the hook is lifted to the stinger position for taxiing. The light goes out when the hook is full down and locked, or retracted with uplock fully engaged. Should the uplock become partly opened (causing illumination of this light) during flight, lower the hook by pulling the arresting hook down control handle and raise to stinger position by pushing the arresting hook up control switch. If the warning light comes on unexpectedly while the airplane is on the ground, have ground crew check hook uplock. Do not taxi further than necessary to clear runway.

#### APPROACH LIGHT.<sup>1</sup>

This light operates in conjunction with the lowering of the arresting hook and serves to aid the landing signal officer to ascertain the airplane attitude during a landing approach. When the exterior lights master switch (figure 1-6) is set to either STEADY or FLASH, with the arresting hook extended and the landing gear locked down, the approach light will glow steadily. With either the hook up or the landing gear not locked down, the approach light will remain out. After landing, the approach light will remain on until the exterior lights master switch is set to OFF.

#### WING APPROACH LIGHTS.<sup>2</sup>

Three wing approach lights, located on the leading edge of the left wing, serve to aid the landing signal officer in ascertaining the airplane attitude during a landing approach. The red approach light glows for a low angle of attack, the amber glows for a medium angle and the green glows for a high angle of attack. The wing approach lights operate without overlap, each light glowing individually to represent the respective angle of attack condition. Since the lights can glow only when the arresting hook and landing gear are down, light operation also informs the landing signal officer that the airplane is in a safe condition for landing. The lights are extinguished when the airplane is on the ground.

## INSTRUMENTS.

The majority of the instruments are installed on the main instrument panel (figures 1-5 and 1-5A). They can be classified into four groups: flight instruments, engine

<sup>1</sup> Airplanes BuNo. 138610a through 138645b.

<sup>2</sup> Airplanes BuNo. 141728c and subsequent.

instruments, navigation instruments and miscellaneous instruments. The flight instrument group includes the accelerometer, airspeed-Mach number indicator, altimeter, rate of climb indicator, turn and bank indicator, gyro horizon indicator, stand-by compass, S-2 remote compass,<sup>2</sup> and MA-1 compass.<sup>1</sup> The engine instrument group comprises the fuel quantity indicator, fuel balance indicator, fuel flowmeter, tailpipe temperature indicator, oil pressure indicator, oil pressure warning light, fuel tank pressure indicator, wing fuel indicator, fin tank fuel indicator and tachometer. The navigation instrument group includes two course indicators. The miscellaneous instrument group consists of the oxygen pressure gage, two separate hydraulic pressure gages,<sup>2</sup> a dual hydraulic pressure gage,<sup>1</sup> a pneumatic pressure gage, wheels and flaps position indicator, slats, flaps and elevators locked indicator, speed brakes position indicator, lateral trim position indicator, longitudinal trim position indicator, cockpit pressure altimeter, radar AFC meter, radar range indicator, angle of attack indicator and voltmeter.

## FLIGHT INSTRUMENTS.

### ACCELEROMETER.

The accelerometer (41, figure 1-5; or 17, figure 1-5A) is located on the main instrument panel. The dial of the instrument is calibrated in "g's" and has a range of minus 5g to plus 10g. The accelerometer is internally and mechanically powered. The instrument has three pointers: One gives a continuous reading which indicates changes of acceleration, the second records the maximum reading obtained and the third records the minimum reading obtained. The last two pointers remain at the highest and lowest reading reached in any particular maneuver and record for future reference the highest positive and negative loads to which the airplane has been subjected. Depressing the knob on the front of the instrument will release the high and low reading hands. This accelerometer is designed to indicate correctly the relatively sustained acceleration experienced in maneuvers such as pull-outs, accelerated turns, etc. It will not indicate accurately the short period accelerations due to shocks encountered in hard landings, taxiing over rough ground or in severe buffeting. In such cases, the indications should be disregarded.

### AIRSPEED—MACH NUMBER INDICATOR.

The airspeed-Mach number indicator (4, figure 1-5; or 6, figure 1-5A) is located on the instrument panel. The indicator is a combination instrument, connected to both static and pitot pressure lines, consisting of an airspeed mechanism and an altitude mechanism. The indicated airspeed mechanism drives a pointer to indicate airspeed on a fixed dial. The pointer also indicates the Mach number on a movable Mach number scale which is driven by the altitude mechanism.

The gearing between the moving scale and the altitude

mechanism is such that the Mach number will be indicated by the pointer on the moving scale at any combination of indicated airspeed and altitude within the range of the instrument. The airspeed indicator has a range of 80 to 650 knots and the Mach number scale has a range of 0.50 to 2.0. The indicator has two triangular indexes, a Mach number setting index and an airspeed setting index. The setting of the Mach number index and the airspeed index is made by the adjustment knob located in the lower left corner of the bezel. The Mach number index is set by depressing and turning the knob and setting the index to the desired Mach number. The Mach number index is not necessarily set at the limit Mach number of the airplane. It is for the pilot's convenience in flying any constant Mach number within the airplane limitations. The airspeed indicator index is set by turning the knob without depressing it and setting the index to any desired airspeed within its range of 80 to 145 knots.

### Note

Either index can be set without changing the setting of the other index.

The following two conditions are given as examples of the operation of the indicator. As the airplane ascends at a constant airspeed, the pointer will remain stationary and the Mach number scale will rotate, indicating an increasing Mach number. As the airplane ascends at a constant Mach number, the Mach number scale and the pointer rotate, with the pointer maintaining its position on the Mach number scale, indicating a constant Mach number and decreasing airspeed.

### ALTIMETER.

The altimeter (6, figure 1-5; or 50, figure 1-5A), mounted on the main instrument panel, indicates the altitude of the airplane in relation to sea level or in relation to a preselected reference point. There are three pointers on the altimeter dial. The large pointer indicates altitude in 100-foot units and completes one revolution for every 1000 feet change in altitude. The second pointer indicates altitude in units of 1000 feet and completes one revolution every 10000 feet, and the third shows the altitude in increments of 10000 feet.

The altimeter dial is calibrated to a standard scale, the zero corresponding to normal sea level atmospheric pressure of 29.92 in. Hg. Because the actual atmospheric pressure for a given altitude may differ from this standard, an adjustment is required to obtain a proper altitude reading. The barometric pressure scale is set according to the existing atmospheric pressure by rotating the knob located at the lower left side of the instrument. The gear system in the instrument shifts the pointer to give correct altitude indications. The altimeter has a range of from zero to 50000 feet and is connected to the static vent line.

<sup>1</sup> Airplanes BuNo. 141728c and subsequent.

<sup>2</sup> Airplanes BuNo. 138610a through 138645b.

## GYRO HORIZON INDICATOR.

The gyro horizon indicator (8, figure 1-5; or 11, figure 1-5A) is located on the main instrument panel. This indicator provides the pilot with a constant visual indication of the pitch and roll attitude of the airplane, using as a reference a stable vertical plane which is maintained by a gyro within the unit. The indicator has a pitch scale visible through a rectangular window located in the center of the instrument. The pitch scale has a range of 0 to 80 degrees for indicating both positive and negative airplane pitch attitudes. The unit operates on three phase, 115 volt, 400 cycle ac from the instrument a-c buses. The circuits are protected by circuit breakers in the a-c circuit breaker panel.

### OPERATION.

Quick erection of the gyro is accomplished by means of a mechanical caging device. To cage the gyro, the caging knob on the front bezel is pulled out and held in the extended position until the horizontal bar and bank index cease to oscillate, at which time they should indicate zero roll and pitch within approximately three degrees. The caging time will depend upon the position of the gyro; however, the longest time will be approximately ten seconds. The caging device cages the gyro to the true attitude of the airplane and not to the true vertical. Therefore, the gyro should be caged only when the airplane is known to be in a straight and level flight condition. The indicator contains a power warning flag that is visible only when the power supply is shut off, if there is an improper phase rotation or an open or short circuit in the instrument.

### CAUTION

The indicator should not be caged in flight unless the airplane is known to be in a straight and level flight. The pilot should not rely upon the indicator for flight indications if the power warning flag is visible in the face of the instrument.

## S-2 REMOTE COMPASS SYSTEM.<sup>1</sup>

The S-2 compass system combines the advantages of the remote indicating magnetic compass and the directional gyro into one instrument. The SLAVED position provides a compass-slaved directional reading which is corrected automatically for gyro precession and eliminates compass oscillation and northerly turning error. Gyro stabilized magnetic compass heading information is fed to the radio magnetic course indicator (12, figure 1-5) where the information is displayed on the compass card. The system uses dc from the primary bus and 115 volt, 400 cycle, three phase ac from the instrument bus. Power is available to operate the system when the d-c power switch is set to BAT. & GEN. or BAT. ONLY.

The S-2 remote compass control panel (14, figure 1-6) is located on the right console. It consists of an an-

nunciator meter marked SYNC IND. which indicates the direction and amount of error between the course indicator reading (gyro) and the magnetic heading (flux valve), a manual slaving control knob marked SET HDG. which is used for synchronizing the gyro and the magnetic heading, and slaving cut-out switch with positions FREE and SLAVED. In the FREE setting, the system operates as a free directional gyro without compass slaving. In the SLAVED setting, the course indicator heading (gyro) will be automatically fast-slaved into alignment with the magnetic heading sensed by the flux valve in about three minutes. Once aligned, the course indicator heading and the magnetic heading of the flux valve should stay in synchronization within one degree and the annunciator pointer will be centered (the annunciator pointer will normally swing out in turns and oscillate in flight). When the slaving cut-out switch is set to FREE, the system is operating as a free gyro. The course indicator heading must be reset periodically to correct for gyro precession. If in a region of reliable magnetic field, the amount of precession to be corrected for is indicated by the annunciator pointer. Moving the manual slaving control knob to R when the annunciator pointer is deflected to the left will precess the gyro and move the course indicator up scale. The annunciator pointer will move towards zero. When the annunciator pointer reaches zero, the gyro heading is synchronized with the magnetic heading and the manual slaving control knob should be moved to its neutral position. When the annunciator pointer is deflected to the right, moving the manual slaving control knob to the L position will move the course indicator heading down scale.

Operating the system as a free directional gyro is useful in polar regions where magnetic headings are unreliable.

### OPERATION.

- a. Set d-c power switch to BAT. & GEN.
- b. With slaving gyro cut-out switch set to SLAVED GYRO, after power has been turned on for three minutes, the annunciator pointer will move away from "hard over" position and become centered on zero, indicating that course indicator heading (gyro) is synchronized with magnetic heading.
- c. Heading on course indicator should be checked with heading on stand-by compass.
- d. When operating near polar regions or on carrier deck, system may be used as a free directional gyro by setting slaving gyro cut-out switch to FREE GYRO.
- e. While operating system as a free directional gyro in a region with a reliable magnetic field, periodically reset course indicator heading to compensate for gyro precession as indicated by annunciator pointer. When pointer is to right of zero, hold manual slaving control knob at DEC. until pointer reaches zero. When pointer

<sup>1</sup> Airplanes BuNo. 138610a through 138645b.



is to left of zero, hold knob at INC. until pointer reaches zero.

f. If in a region with an unreliable magnetic field such as polar regions, a known precession rate may be used to reset system, or other navigational bearing information may be used as a standard.

### MA-1 COMPASS SYSTEM.<sup>1</sup>

The MA-1 compass system combines the advantages of the remote indicating magnetic compass and the directional gyro into one instrument. The system may be operated as a magnetically slaved instrument or as an unslaved gyro. The SLAVED position provides a compass-slaved directional reading on the radio magnetic course indicator (13, figure 1-5A) on the pilot's instrument panel. The system uses dc from the primary bus and 115 volt, 400 cycle, three phase ac from the instrument bus. When the d-c power switch is set to BAT. & GEN. or BAT. ONLY, the MA-1 compass is electrically powered to operate as either a slaved or free system, depending on the initial setting of the SLAVED-FREE selector switch. The MA-1 compass control panel (14, figure 1-6) is located on the right console. It consists of a SYNC. IND. meter which provides visual indication of the lack of synchronization between the directional gyro and the magnetic heading reference (flux valve), a manual slaving control switch marked SET HDG. which is used to initially orient the compass system to the indicated heading in a maximum time of 15 seconds, a slaving cut-out switch marked SLAVED-FREE which determines the mode of operation of the compass system, and a LAT. CONT. knob which is used only during free operation of the compass system. In the FREE setting, the system operates as a free directional gyro without compass slaving. In the SLAVED setting, the compass indicator heading (gyro) will automatically be slaved into alignment with the magnetic heading sensed by the flux valve at a rate of approximately two degrees per minute. Once aligned, the compass indicator heading and the magnetic heading of the flux valve should stay in synchronization and the pointer of the synchronization indicator will be centered.

The slaving system becomes unusable above 60° latitude or when large quantities of iron or steel are in close proximity, which would cause deviation of the earth's magnetic field. When such conditions exist, the MA-1 compass may be operated as a free directional gyro and, as such, the existing latitude must be set on the controller with the LAT. CONT. knob.

### OPERATION.

a. With SLAVED-FREE switch in SLAVED position, set d-c power switch to BAT. & GEN.

b. Use SET HDG. switch to initially orient compass system to indicated heading. Movement of switch to either R or L causes synchronization indicator needle

to move and compass indicator to change its directional information at a rate of 12 degrees per second. The compass system will now maintain its heading reference with earth's magnetic field.

c. When such conditions exist that slaving system becomes unusable, system may be used as a free directional gyro by setting SLAVED-FREE switch to FREE position and LAT. CONT. switch to NORTH or SOUTH latitude in which flight is started.

d. Using SET HDG. switch, orient compass indicator to a fixed point in space of known direction. This point now becomes aircraft heading reference.

e. During flight, LAT. CONT. must be changed to compensate for each five degree change in latitude as it is reached.

## CANOPY.

### CANOPY CONTROLS—NORMAL AND EMERGENCY.

A combination canopy control lever (59, figure 1-5; or 62, figure 1-5A), located on the left side of the cockpit above the landing gear normal controls, is moved forward to CLOSE and aft to OPEN for normal operation of the canopy. A third position, labeled JETTISON, provides an emergency means of jettisoning the canopy (see Emergency Ejection Procedure, Section III). A jettison locking lever (58, figure 1-5; or 61, figure 1-5A) is attached to the canopy control lever. Squeezing the two levers together makes it possible to place the canopy control lever in the JETTISON position. A ground safety lock is provided to prevent inadvertent closing of the canopy when the canopy control lever is in the OPEN position.

## PILOT'S EJECTION SEAT.

The ejection seat consists of a stationary back with a fixed headrest attached, footrests and a movable bucket. Also attached to the ejection seat are the MS16036 automatic lap belt, shoulder harness, electric shoulder harness inertia reel, manual seat height control, inertia reel control handle, face curtain and the ejection seat emergency arming handle (see figure 1-15A). The lap belt is provided with a cartridge which will open the belt three-quarters of a second after the seat catapult is fired.

### WARNING

If the lap belt firing mechanism is inadvertently actuated with the cartridge installed, the belt assembly must be removed and replaced by the deck crew prior to the next flight.

An automatic parachute opener (attached to the lap belt) will release the parachute at a preset altitude. If ejection is made below the preset altitude, the automatic

<sup>1</sup> Airplanes BuNo. 141728c and subsequent.

# EJECTION

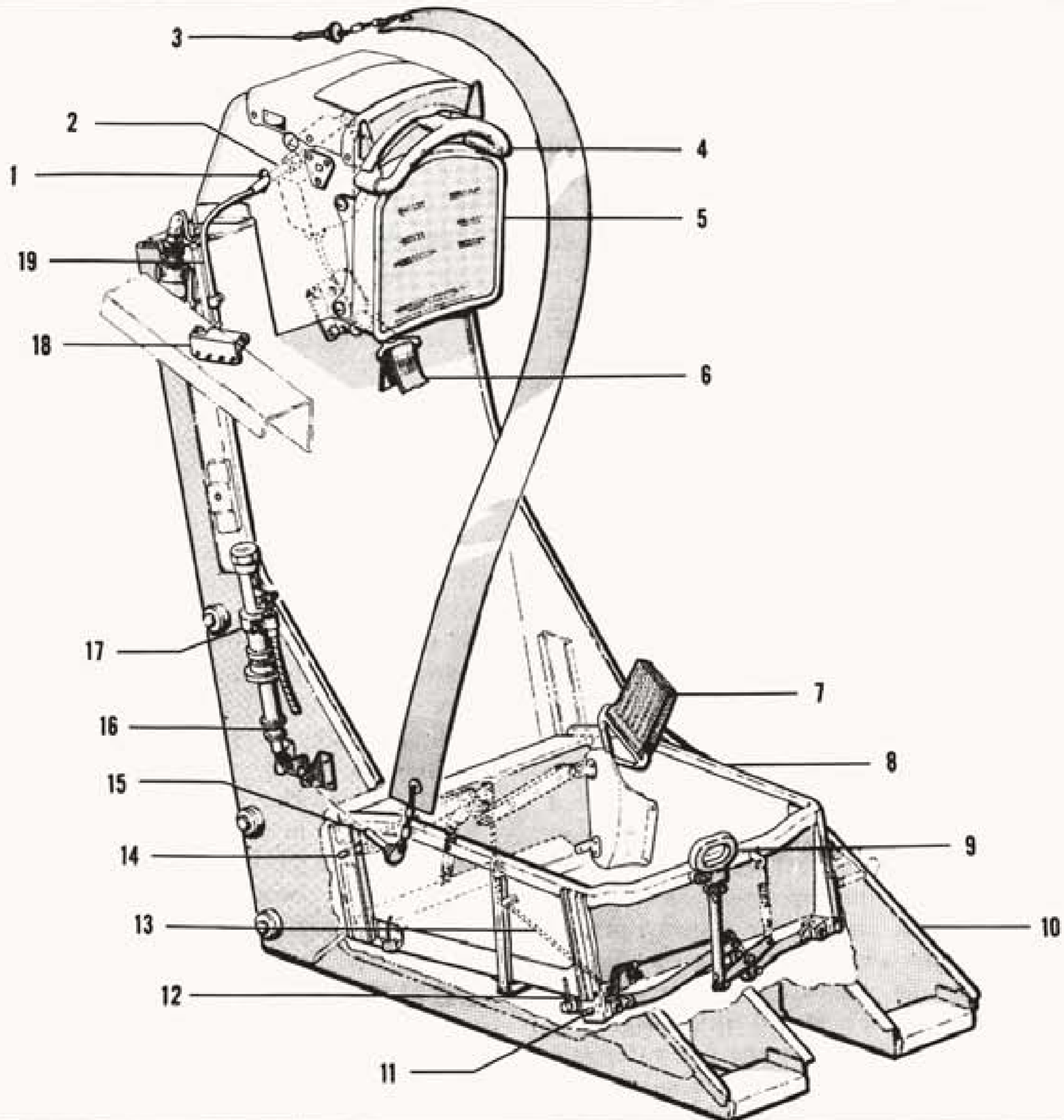

- |                                     |  |  |
|-------------------------------------|--|--|
| 1. Firing Cable Inspection Hole     | 8. Seat Bucket                                 | 14. Height Adjustment Locking Pin                  |
| 2. Shoulder Harness Inertia Reel    | 9. Bucket Height Control (Locking Pin Release) | 15. Automatic Lap Belt Actuator Ground Safety Lock |
| 3. Ejection Seat Ground Safety Lock | 10. Foot Rest                                  | 16. Sear Actuator                                  |
| 4. Face Curtain Handle              | 11. Height Adjustment Locking Pin              | 17. Automatic Lap Belt Actuator                    |
| 5. Headrest                         | 12. Bucket Counterbalance Cable                | 18. Sear Actuator Striker                          |
| 6. Shoulder Harness                 | 13. Locking Pin Control Cable                  | 19. Inertia Reel Control Cable                     |
| 7. Lap Belt                         |  |  |

Figure 1-15A. Grumman Ejection Seat (Sheet 1)

## SEAT

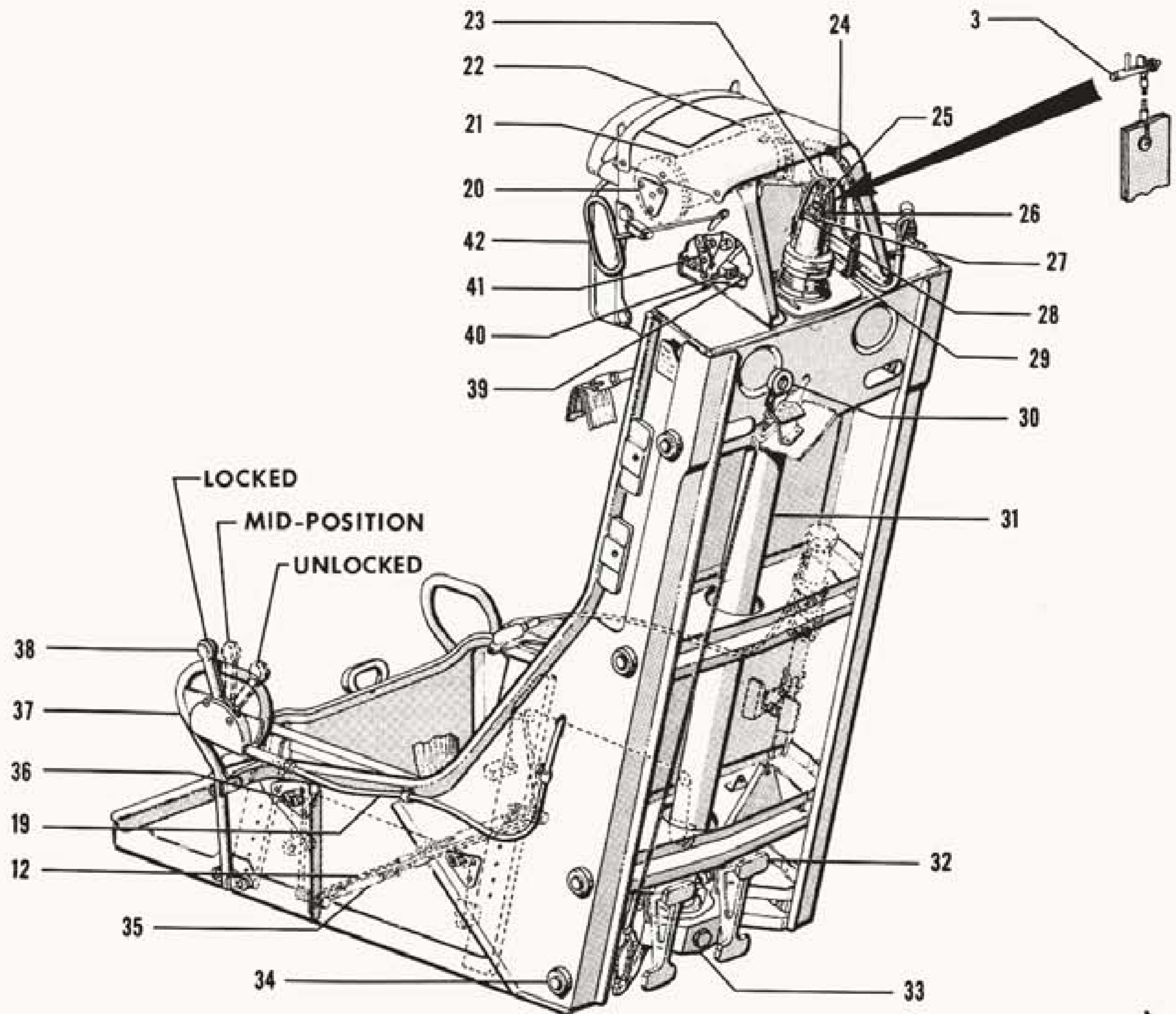

- |                                   |                                   |  |
|-----------------------------------|-----------------------------------|--|
| 20. Face Curtain Roller Bearing   | 28. White Line                    | 37. Knee Brace                                       |
| 21. Face Curtain Roller Spring    | 29. Cable Spring                  | 38. Harness Inertia Reel Control Handle              |
| 22. Face Curtain Roller           | 30. Seat Disconnect Ring          | 39. Canopy Jettison Control Cable                    |
| 23. Firing Mechanism Yoke         | 31. Catapult Tube                 | 40. Canopy Jettison System Square Tube and Clamshell |
| 24. Catapult Firing Cable         | 32. Bulkhead Seat Support Fitting | 41. Canopy Jettison Control Assembly                 |
| 25. Firing Cable Disconnect       | 33. Catapult Support Fitting      | 42. Ejection Seat Emergency Arming Handle            |
| 26. Safety Pin                    | 34. Seat Roller                   |  |
| 27. Red Cartridge Indicating Band | 35. Bucket Counterbalance Spring  |  |
|                                   | 36. Counterbalance Pulley         |  |

Figure 1-15A. Grumman Ejection Seat (Sheet 2)

opener will operate after a preset time delay following separation of pilot and seat.

### NORMAL CONTROLS.

#### BUCKET HEIGHT CONTROL.

A ring handle (7, figure 1-7; or 9, figure 1-15A), located on the forward edge of the bucket between the pilot's legs, controls the raising and lowering of the bucket. Pulling the ring up releases four locking pins. Then, to adjust the bucket to the desired height, the pilot either applies downward pressure on the bucket with his body (to lower) or raises his body above the seat to release pressure and allow the bucket to come up higher. To hold the bucket in the selected position, the locking pins are reengaged by allowing the ring handle to return to its normal position.

### EMERGENCY CONTROLS.

#### FACE CURTAIN HANDLE (SEAT CATAPULT FIRING CONTROL).

This handle (3, figure 1-7; or 4, figure 1-15A) is located just above the pilot's headrest and is attached to the face curtain, which is stowed on a roller behind the headrest. To eject, the pilot should first place his feet on the footrests, then pull the face curtain handle forward and down until it stops. This jettisons the canopy. The handle cannot be pulled further until the canopy has jettisoned. After the canopy is away, the handle is pulled down further until it pulls the safety pin and catapults the seat.

The catapult cartridge indicating mechanism is located on top of the catapult tube. When a cartridge is in the catapult tube, a cap on top of the mechanism will project slightly to expose the word **LOADED** (in white) and a white line around the side of the cap.

#### EJECTION SEAT EMERGENCY ARMING HANDLE.

This red emergency ejection seat arming handle (4, figure 1-7; or 42, figure 1-15A), located on the left side of the headrest (2, figure 1-7; or 5, figure 1-15A), permits ejection through the canopy if the face curtain fails to jettison the canopy. Pulling this handle forward disconnects the canopy jettison system and permits the face curtain to be pulled through the full range of travel required to fire the seat catapult.

### AUTOMATIC LAP BELT AND PARACHUTE OPENERS.

The lap belt is provided with an automatic opener which is actuated three-quarters of a second after the seat catapult is fired. The parachute is equipped with an automatic barometric opener which is activated upon separation of pilot and seat. If ejection occurs above the preset altitude, opening of the parachute is barometrically delayed until the pilot descends through that altitude. If ejection occurs below the preset altitude, opening of the parachute will occur after a preset time delay following separation from the seat.

### AUTOMATIC LAP BELT OPERATION.

The MS16036-2A cartridge actuated automatic lap belt (figure 1-15B) installed on the right side of the ejection seat automatically releases the pilot from the seat three-quarters of a second following ejection. The lap belt is actuated by a three-quarter second delay cartridge which is fired when the seat is ejected. The cartridge is fired as the lap belt actuator, located on the right side of the ejection seat, is tripped by the striker located on the right side of the cockpit.

### WARNING

If the belt fails to open automatically following ejection, the pilot must release the belt manually. In addition, the parachute must now be actuated manually since manual opening of the automatic lap belt detaches the automatic parachute actuation cable.

### CAUTION

The belt assembly is designed as a "one-shot" installation. In the event of inadvertent actuation of the firing mechanism with the cartridge installed, the actuating assembly (consisting of the actuator assembly and actuating unit assembly) will distort due to powder pressure and it cannot be re-used. The following procedure shall apply: Remove the belt assembly and install a new belt assembly procured from local stock.

### HARNESS INERTIA REEL SYSTEM.

The harness inertia reel system incorporates a spring loaded reel containing a cable which is connected to the straps of the pilot's shoulder harness. The unit is electrically controlled by a circuit from the battery d-c bus through the harness reel circuit breaker. In the circuit is a harness reel inertia switch which opens the circuit when the switch senses 2-1/2g or more in any direction except vertically down. The open circuit de-energizes and locks the reel, thus preventing cable extension and forward movement of the shoulder harness.

#### Note

When the locking action occurs, only the forward movement of the shoulder harness is prevented. Any aft movement will be absorbed by the spring load within the reel. After any aft movement, however, the reel is still locked and prevents forward movement from the new position.

### HARNESS INERTIA REEL CONTROL HANDLE.

A manually operated control handle (6, figure 1-7; or 38, figure 1-15A) with locked and unlocked positions is provided on the left leg brace. In the locked (forward) position, the cable reel is mechanically locked,

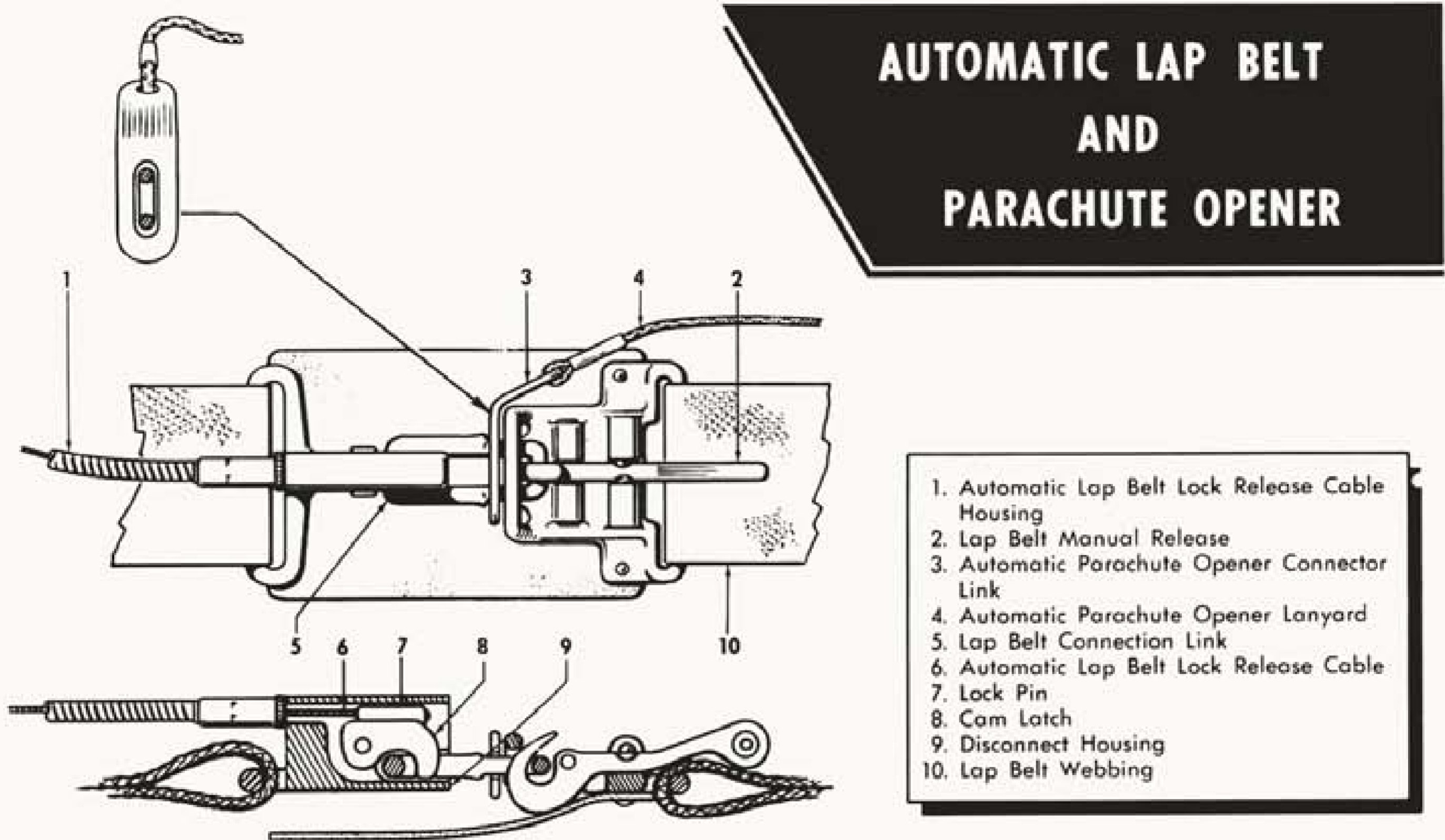

Figure 1-15B. Automatic Lap Belt and Parachute Opener

overriding all electrical operation. When the control handle is in the unlocked position, the reel is free until the inertia switch is operated, which locks the reel. The reel will remain locked until the control handle is moved to the locked (forward) position and replaced to the unlocked (aft) position (provided the excessive inertia forces are no longer present). The cable reel may be released and the shoulder harness slackened, if necessary, upon electrical power failure, by moving the control handle to a position midway between locked and unlocked.

### FIRE DETECTION SYSTEM.

This is a continuous type, automatic resetting detector which provides a warning to the pilot if a fire occurs in the engine accessory section. It consists of a warning light, test relay, control unit, sensing elements and connectors. It is powered by 115 volts ac from the instrument bus. The sensing elements are attached to the fuselage in three running loops around the engine and constitute the input of a triggering circuit in the control unit. In normal condition, they present a circuit resistance high enough to prevent illumination of the warning light. However, excessive heat near any element will break down the resistance of the ceramic insulators in the sensing elements and reduce the circuit resistance to complete the circuit ground. This will cause the warning light to glow. Both ends of the continuous element are connected to the control unit so

that a single break anywhere in the element will not impair system operation.

### FIRE WARNING LIGHT CIRCUIT TEST SWITCH.

A fire warning light circuit test switch (20, figure 1-5; 23, figure 1-5A) is located on the repeater oxygen blinker panel. This switch supplies d-c power to close the test relay, shorting the sensing elements and simulating a fire condition to illuminate the warning light.

### FIRE WARNING LIGHT.

A fire warning light (14, figure 1-5; or 14, figure 1-5A) is located on the instrument panel. The light is energized by the fire sensing elements in the event of an engine accessory compartment fire. The light will glow when the fire warning light circuit test switch is actuated, indicating that the fire warning circuit is in working order. When illuminated, the light reads FIRE.

### AUXILIARY EQUIPMENT.

The following systems are discussed in Section IV:

Air Conditioning System

Oxygen System

Lighting Equipment

Communication and Associated Electronic Equipment

Navigation Equipment

Armament

# Servicing Diagram

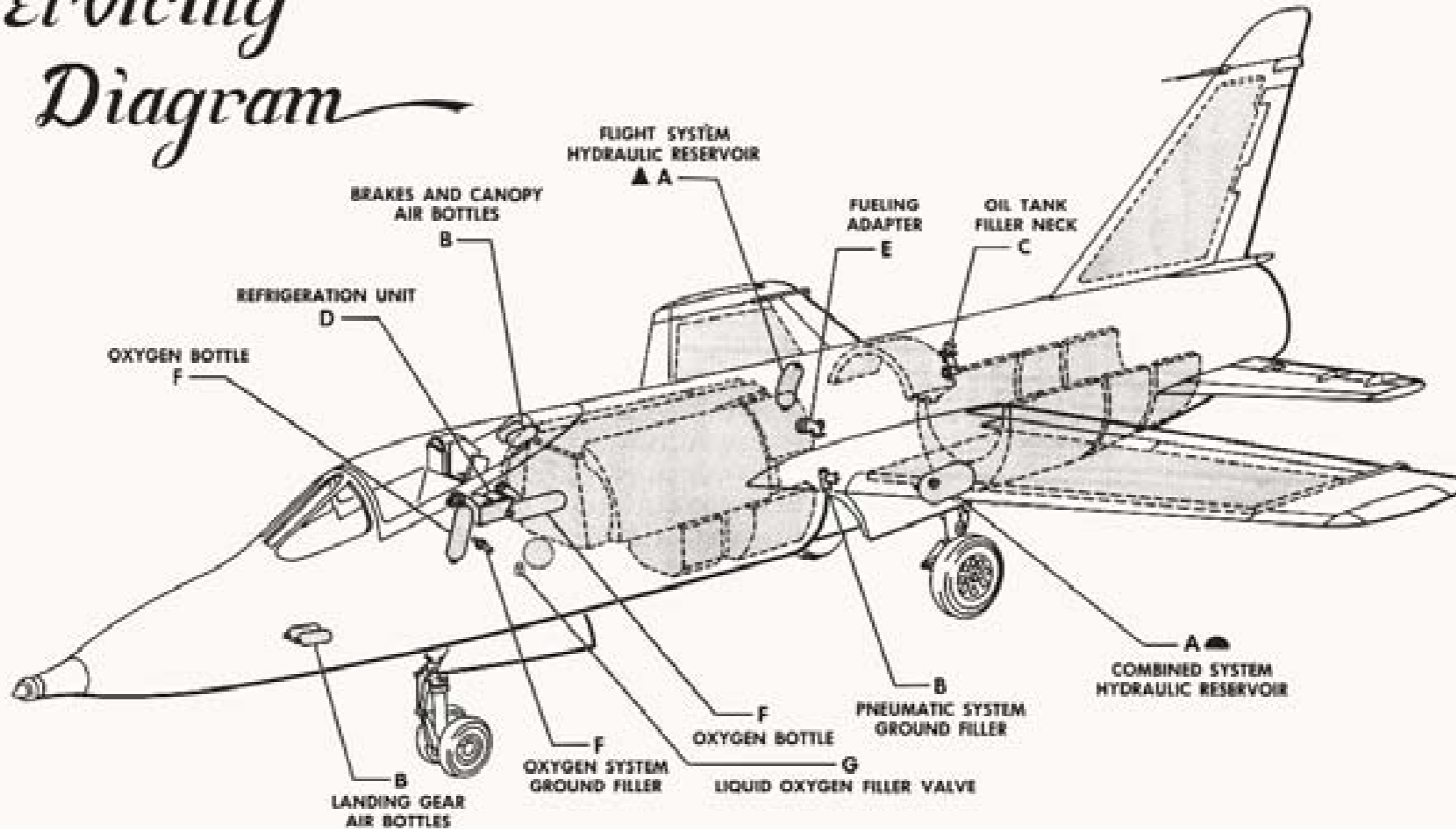

## A HYDRAULIC FLUID

▲ Flight System  
 Spec MIL-H-5606 Red Fluid  
 Total System Capacity 2.42 gal  
 Reservoir Capacity 1.93 gal  
 Refill Capacity 1.87 gal

## ● Combined System

Spec MIL-H-5606 Red Fluid  
 Total System Capacity 7.72 gal  
 Reservoir Capacity 4.14 gal  
 Refill Capacity 3.82 gal

## B PNEUMATIC SYSTEM

Dry Compressed Air 3000 PSI  
 Note

All pneumatic system bottles are serviced from the ground filler

## C OIL

Spec MIL-L-7808  
 Tank Capacity 3 gal

## D REFRIGERATION UNIT

Spec MIL-L-6085  
 Sump Capacity 8.5 cc  
 Check oil level at 250 hr flight time.  
 Note: When checking oil level-replace retainer "O" ring on cap

## E FUEL

APPROVED FUELS*	Ashore JP-4 JP-3
	Afloat JP-5
EMERGENCY FUEL	AV GAS

For fuel quantities, see Figure 1-7A.  
 \*Approved fuels though considered equivalent are listed in preferential order.

### Caution

The use of Avgas is not recommended. It may be used only in an emergency. A hot section inspection is required after its use.

## F GASEOUS OXYGEN<sup>1</sup>

Fill with oxygen, FED. Spec BB-O-925, to 1800 ±50 psi. Oxygen bottle capacity 514 cu in.

## G LIQUID OXYGEN<sup>2</sup>

FED. Spec BB-O-925  
 Converter Capacity 5.28 US Quarts (5 Liters)

<sup>1</sup>Airplanes BuNo. 138610a through 141750c.

<sup>2</sup>Airplanes BuNo. 141751d and subsequent.

Figure 1-16. Servicing Diagram

# Section II



## NORMAL PROCEDURES

### BEFORE ENTERING THE AIRPLANE.

- a. See Section V, and check latest service directives and orders for limitations imposed on this airplane.
- b. Determine weight and balance status of airplane. Obtain take-off and anticipated landing gross weights. Have useful load checked. Be sure proper ballast is aboard.

#### Note

Refer to the Handbook of Weight and Balance, AN 01-1B-40, for loading information.

### EXTERIOR INSPECTION.

Consult Yellow Sheet for status of airplane and make sure airplane has been properly serviced.

#### Note

In ground pressure fueling, the plane captain and pilot can determine, prior to take-off, that the wing tanks and aft tank are full by means of the three fuel station check lights. There is one light for each wing tank and one for the aft tank. When these lights are extinguished, their corresponding fuel tanks are full. The drop tanks can be checked visually for full fuel through the inspection window on each tank.

Starting at the front of the airplane perform an exterior inspection (see figure 2-1). For danger areas, see figure 2-3.

### ENTRANCE TO AIRPLANE.

For instructions on entering the airplane, see figure 2-2.

### CANOPY AND EJECTION SEAT CHECK.

Before becoming seated in the airplane, make the following checks:

- a. Canopy control lever—in OPEN position.
- b. Cartridge—properly shows white line below red cartridge indicating band (loaded) of catapult firing head on top of seat; firing cable is fastened to safety pin disconnect; ground lock tool is removed from catapult firing yoke.
- c. Seat position—arrow on seat lines up with bottom edge of painted yellow stripe on seat rail.
- d. Firing cable—visible through inspection hole on right side of headrest.
- e. Lap belt—static line is connected to lap belt actuator on right side of seat above console; inspect lap belt actuator for lockwiring.

### ON ENTERING AIRPLANE.

#### INTERIOR CHECK—ALL FLIGHTS.

- a. Seat belt and shoulder harness fastened; auto chute cable attached; seat bucket adjusted to align eyes to eye level line; oxygen, "G" suit, and radio leads attached; cockpit clear and everything stowed.
- b. All switches and controls off, safe or normal. "G" suit valve—HI or LO, as desired. Fire control system, AN/APG-30—OFF. Wheel brakes emergency control handle—stowed.

# EXTERIOR

# INSPECTION

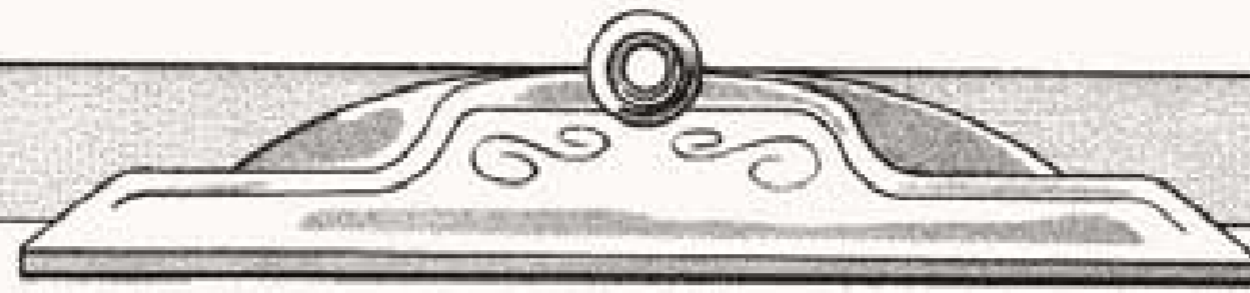

## 1 NOSE

- Overall view of airplane.
- Landing gear chocked.
- Overall view of nose gear indicates no obvious defects.
- Nose gear tires and shock strut properly inflated.

## 2 FUSELAGE - FORWARD RIGHT SIDE

- Access doors closed.
- Intake duct unplugged and clean.
- Overall view of main landing gear indicates no obvious defects.
- Main gear tire and shock strut properly inflated.
- Fuel inlet cover secured.

## 3 RIGHT WING

- Wing tank ram air inlet duct uncovered and clean.
- Wing tip up and locked, and undamaged.
- Wing tank dump port unobstructed.
- Wing flap undamaged.

## 4 FUSELAGE - AFT RIGHT SIDE

- Generator cooler and oil vapor outlets unobstructed.
- Secondary air inlet ducts unobstructed.
- Arresting hook stowed.

## 5 STABILIZER - RIGHT SIDE

- Elevator hinge points secured and safetied. No elevator play permissible.
- Stabilizer fairings intact, screws in place and no deformation of fairing itself.
- Pitot head uncovered and undamaged.

## 6 STABILIZER - LEFT SIDE

- Reverse procedure given for stabilizer-right side.

## 7 FUSELAGE - AFT LEFT SIDE

- Secondary air inlet ducts unobstructed.

## 8 LEFT WING

- Reverse procedure for right wing.

## 9 FUSELAGE - FORWARD LEFT SIDE

- Main gear tire and shock strut properly inflated.
- Overall view of main landing gear indicates no obvious defects.
- Intake duct unplugged and clean.
- Access doors closed.



Figure 2-1. Exterior Inspection Diagram



# ENTRANCE TO AIRPLANE



## ENTRANCE TO AIRPLANE (STEP PROCEDURE)

1. Operate step release handle to release boarding ladder and pop-out step.

### WARNING

Stand clear of ladder and step when operating step release.

2. Pull canopy control handle (on left intake duct beneath access door) down to open canopy. Secure access door.
3. Place left foot on bottom rung of ladder.
4. Grip duct plate with right hand.
5. Grasp pop-out step with left hand.
6. Swing up to bring right foot to upper rung of ladder, moving right hand to canopy rail.
7. Raise left foot onto pop-out step.
8. Grip windshield frame with left hand.
9. Swing up and enter cockpit with right foot.

### CAUTION

The boarding ladder and step cannot be stowed from the cockpit. Before flight, be sure ladder and step are pushed in and stowed by ground crew.

Emergency hydraulic turbine control handle—stowed.  
 A-C circuit breakers—in.  
 Speed brakes override switch—NORM.  
 Afterburner nozzle override switch—AUTO.  
 Yaw damper and rudder trim switch—OFF.  
 Airstart ignition switch—OFF.  
 Power control lever—OFF.  
 Power control lever grip—gunsight caged position.  
 Flaps control handle—UP.  
 Wing fuel dump switch—NOR.  
 Engine fuel control switch—AUTO.  
 Fuel tank emergency selector switch—NOR.  
 Fuel Tank Pressure switch—ON.  
 Wing fuel transfer switch—FIN & WING TRANS.  
 Oxygen supply control at regulator—ON; check regulator and equipment.  
 Armament master switch—OFF.  
 Gun control switch—SAFE.  
 Landing gear control lever—DOWN.  
 Rudder pedals—adjust.  
 Altimeter—set.  
 Clock—set.  
 Pneumatic pressure gage—2800 to 3000 psi.  
 Hydraulic system isolation control lever—TAKE-OFF

Figure 2-2. Entrance to Airplane

**LANDING.**

S-2 compass<sup>1</sup>—SLAVED.

MA-1 compass<sup>2</sup>—SLAVED.

D-C circuit breakers—in.

Communication, navigation and IFF equipment—OFF.

Cabin pressurization—as desired.

Instrument power switch—EMERG.

AN/ARC-27A—T/R or T/R+G.

c. D-C power switch—BAT. & GEN.

**Note**

Set d-c power switch to BAT. & GEN. (before connecting external power) to check battery. Voltmeter must read a minimum of 23 volts.

Instrument power switch—NORMAL.

Landing gear indicator—check down and locked.

External power and starter air supply—have ground crew connect.

Fuel master switch—ON; low pressure fuel pump warning light—observe. (Low pressure fuel pump warning light will glow until fuel master switch is turned on. The fuel master switch activates submerged electric boost pump. When pressure builds up, light will go out. If light does not go out, fueling station master switch in right wheel well should be checked.)

Engine master switch—ON (high pressure fuel pump warning light should glow).

Warning lights test switch—press (all warning lights should glow except fire warning light).

Fire warning light circuit test switch—press (fire warning light should glow).

Fuel quantity indicator test switch—press (fuel quantity indicator pointer and fuel balance indicator pointer should move down scale; upon release, pointers should return to their original positions).

Wing fuel indicator and fin fuel indicator—check (both indicators should show "barber pole" position except when completely full or empty).

Boost pump cut-off switch—press (low pressure pump warning light should glow after 30-45 seconds).

Radio and navigation equipment—ON; IFF—STANDBY.

Yaw damper and rudder trim switch—ON.

**INTERIOR CHECK—NIGHT FLIGHTS.**

All the checks covered under INTERIOR CHECK—ALL FLIGHTS apply here. Also, a check of the night lighting provisions should be accomplished after external power is connected.

a. Set respective instrument and console lights switches to DIM and MED and check light intensities.

b. Set emergency bright control switch to BRIGHT. Check that instrument and console lights become bright. Return switch to NORMAL position.

c. Set individual exterior lights switches to BRT and set exterior lights master switch to its STEADY and FLASH positions, pausing at each position to check operation of exterior lights. Set individual exterior lights switches to DIM and repeat check.

d. Set fuselage lights switch to MAN, with master switch set to STEADY or FLASH. Operate manual keying switch and check that fuselage lights and keying indicator light glow when keying switch is depressed.

e. Install antiglare shield if desired.

f. Check operation of utility light.<sup>3</sup>

**BEFORE STARTING ENGINE.**

a. Check that personnel are clear of tailpipe and intakes.

b. Check that starter rig is running and that air supply is available.

**STARTING ENGINE.****CAUTION**

PILOT CONTROLLED STARTS are recommended. Electrical connection from the aircraft starter circuit external receptacle AN3100-14S-2P, located in the left wheel well, to the gas turbine ground power unit is to be made prior to starting to insure automatic shut-off of the air supply at the correct starter cut-out speed. HAND SIGNALS or GROUND CONTROLLED STARTS are not recommended for initiation and/or shut-off of the ground air supply. Time delay inherent in this method may result in overspeed of the starter causing failure or damage. Failure of a starter due to overspeed could be hazardous to operating personnel. If automatic shut-off of the air supply cannot be achieved due to malfunction of equipment, pilots and crewmen are cautioned that the starter air supply must be manually shut off at a speed not to exceed 30% engine rpm. The control valve in the gas turbine ground power unit WILL NOT shut off the air supply automatically unless the unit is connected electrically to the aircraft starting circuit.

a. Check that power control lever is at OFF.

b. Check that d-c power switch is at BAT. & GEN.

c. Check that fuel master switch is set to ON.

d. Check that engine master switch is ON.

<sup>1</sup> Airplanes BuNo. 138610a through 138645b.

<sup>2</sup> Airplanes BuNo. 141728c and subsequent.

<sup>3</sup> Airplanes BuNo. 141728c and subsequent.

- e. Set engine fuel control switch to AUTO.
- f. Move power control lever to START to initiate engine cranking.
- g. As soon as engine reaches 12 to 14% rpm during the cranking operation, advance power control lever to IDLE position.

#### Note

Higher rpm's give cooler starts.

h. When light-off occurs, allow engine to accelerate to IDLE rpm (42-44% rpm, maximum starting tailpipe temperature 800°C, maximum idle tailpipe temperature 660°C). If maximum temperature is anticipated or obtained, such as under hot ambient conditions, retard power control lever as necessary toward OFF to reduce starting fuel while monitoring exhaust gas temperatures. After the exhaust gas temperature has dropped from the maximum limit, advance the power control lever carefully to IDLE, monitoring the exhaust gas temperature to keep from exceeding the limit. On some airplanes,<sup>1</sup> it is also possible to alleviate hot starts by placing the exhaust nozzle override switch in the OPEN position.

### WARNING

EXTREME CAUTION should be used with this method to insure the return of the override switch to the NORMAL position after the engine has been successfully started.

If the power control lever is closed inadvertently during engine operation, there will be an immediate flame-out which will be impossible to catch, regardless of how quickly the power control lever is reopened. DO NOT TRY TO REGAIN IGNITION BY REOPENING THE POWER CONTROL LEVER since raw fuel will be sprayed out of the tailpipe and create a dangerous condition. A standard start or relight procedure will be necessary to restart the engine.

### CAUTION

If tailpipe temperature exceeds 800°C, a hot start has occurred—IMMEDIATELY close power control lever. The cause of a hot start should be ascertained and the possible resultant damage should be surveyed before a restart is attempted. If any start exceeds 900°C, a special "hot section" inspection is required as outlined in the engine Handbook of Service Instructions (AN 02B-35AAC-2).

#### Note

If trouble is encountered while attempting to

start on AUTO, set engine fuel control to MANUAL. After a successful start is accomplished on MANUAL, switch over to AUTO when performing engine check (see Engine Check paragraph).

- i. Check high pressure fuel pump warning light off before idle rpm is attained.
- j. Check oil pressure gage for proper reading. (See Section V for oil pressure limits.)
- k. When rpm stabilizes in idle, disconnect external power supply.
- l. Extend flaps to provide maximum rudder pedal travel to facilitate nose wheel steering.

#### FALSE STARTS.

If light-up does not occur within 15 seconds after advancing power control lever to IDLE or if engine fails to accelerate to idle rpm within approximately one minute after light-up, proceed as follows:

- a. Set power control lever to OFF.
- b. Set engine master switch to OFF.
- c. When engine stops rotating, set fuel master switch to OFF and investigate.

#### CLEARING ENGINE.

- a. Set engine master switch to ON.
- b. Set fuel master switch to ON.
- c. Move power control lever outboard to START. Do not advance power control lever.
- d. Allow starter to operate engine at 12 to 14% rpm for 30 seconds to clear engine.
- e. Set engine master switch to OFF to stop engine cranking.

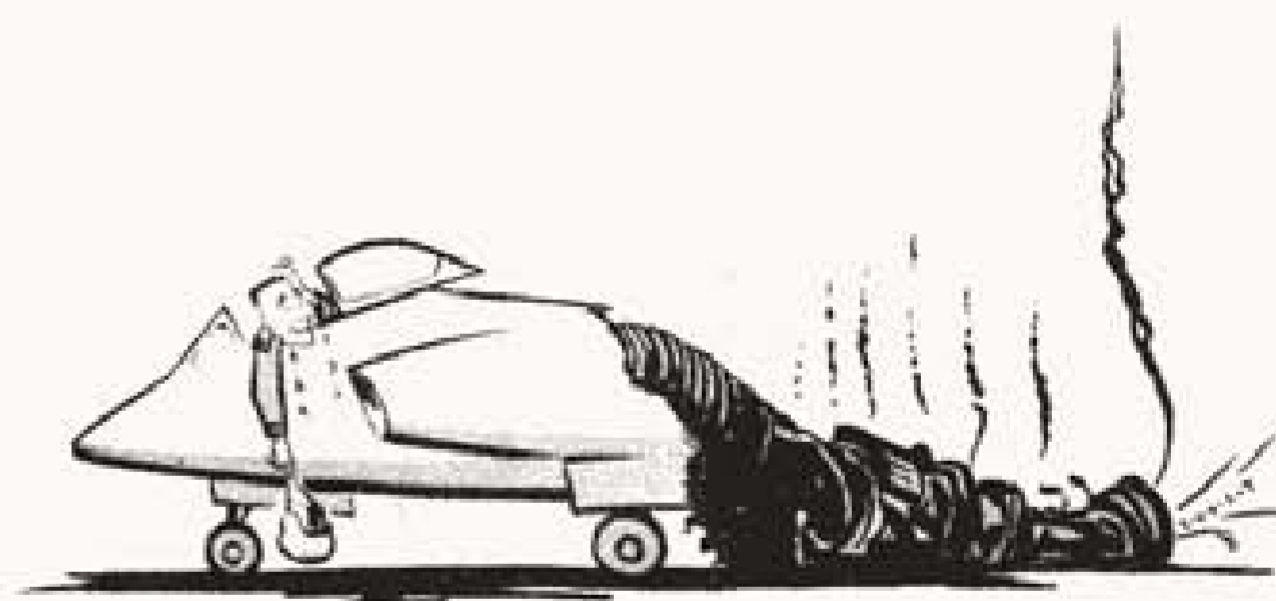

#### HOT STARTS.

A hot start is a condition occurring during a starting attempt wherein the tailpipe temperature soars above normal. It may be caused by a malfunction of the fuel metering system or by faulty starting procedure, but it is the direct result of one condition—an excess of fuel in the combustion chamber. Use only the approved starting procedure for starting the engine. When a hot start occurs, observe the following procedure:

- a. Set power control lever to OFF. This will cut off

<sup>1</sup>Airplanes BuNo. 141751d and subsequent.

# DANGER AREAS

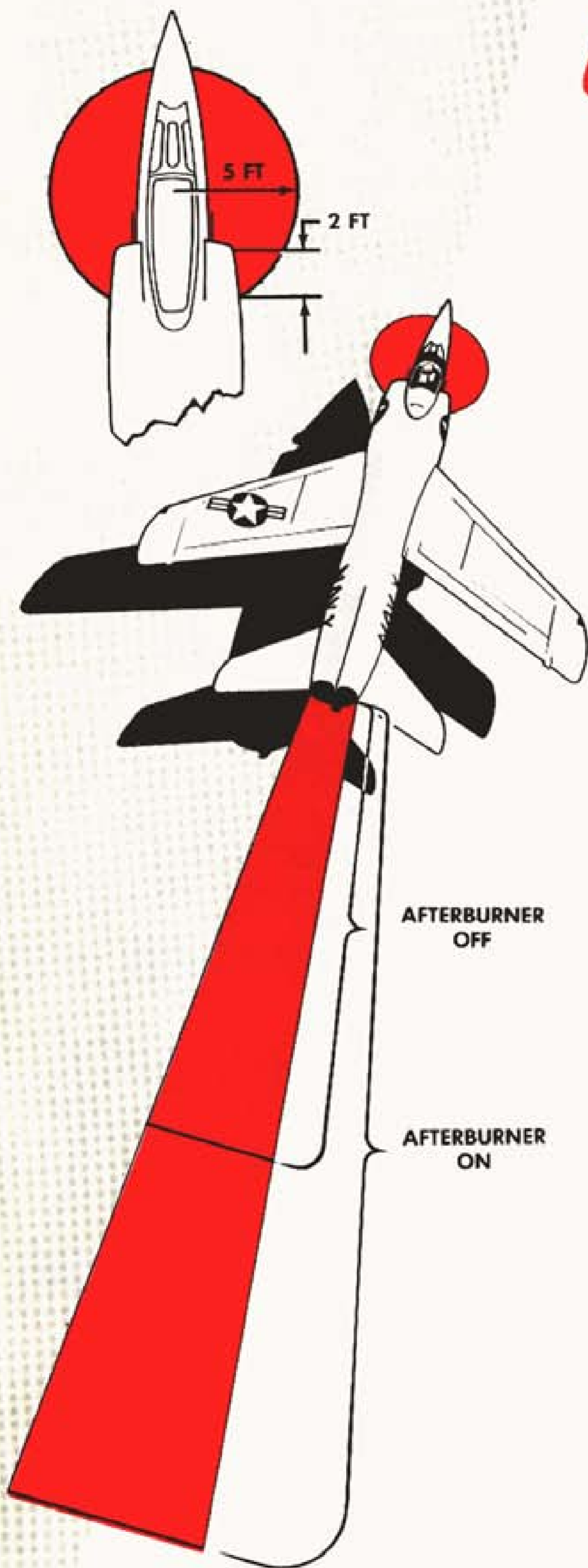

AT MAXIMUM THRUST ...		
	MAXIMUM EXHAUST TEMPERATURE	EXHAUST DANGER AREAS
AFTERBURNER OFF	130° F	100 FT
AFTERBURNER ON	150° F	200 FT

fuel flow to engine. When engine rpm drops into 27-29% range, starter will pick up the engine.

**Note**

If the engine was below the 27-29% rpm range during the start, the starter was still driving it.

b. Allow starter to rotate engine for 30 seconds to clear engine.

c. Set engine master switch to OFF. When engine stops rotating, set fuel master switch to OFF.

d. After investigation, if it has been determined that hot start was caused by other than a system malfunction, attempt to restart. Any start exceeding 800°C must be noted on the yellow sheet. If one start exceeds 900°C, a special inspection is required as outlined in Handbook of Service Instructions for engine.

**Note**

For procedure to be followed in case of fire, see Fire paragraph, Section III.

**RUNAWAY STARTS.**

A runaway start is a rare occurrence, but can be encountered if the fuel control malfunctions or if a section of the power control linkage is disconnected. In such a case, the engine must be stopped by cutting off the fuel supply from the tanks to the engine. This is done by setting the fuel master switch to OFF (d-c power switch must be set at BAT. & GEN. or BAT. ONLY).

**ENGINE GROUND OPERATION.**

**WARM-UP.**

a. Allow engine to run at idling speed (42-48%

Figure 2-3. Danger Areas

rpm) for approximately 30 seconds, as a normal stabilizing period.

b. With power control lever set at IDLE, check the following:

Tachometer—42-48% rpm.

Tailpipe temperature indicator—660°C maximum.

Oil pressure indicator—NORMAL.

Oil pressure warning light—out.

## GROUND TESTS.

### HYDRAULIC SYSTEM.

Check that flight and combined hydraulic system gages each indicate 3000 psi.

### FLIGHT CONTROL SYSTEMS CHECK.

#### FLAPS UP.

a. Operate rudder, stabilizer and flaperons to check artificial feel systems. Observe movement of control surfaces.

b. Set yaw damper and rudder trim switch to ON and have ground crew check operation of rudder trim. Set to zero.

c. To check lateral trim system, move trim switch on stick to left and right, holding stick fixed. Observe change in stick force required. Repeat check, allowing stick to move to left and right corresponding to trim switch settings. Observe lateral trim position indicator on stick and set lateral trim to zero.

d. To check longitudinal trim system, move trim switch fore and aft, holding stick fixed. Observe change in stick force required. Repeat check, allowing stick to move fore and aft corresponding to trim switch settings. Observe longitudinal trim position indicator and set trim to five degrees airplane nose-up trim.

e. Set isolation system control lever to TAKE-OFF LANDING, set flaps control lever to DOWN and check that flaps go down.

#### FLAPS DOWN.

a. Check that flaperons automatically trail up to six degrees.

b. Check that slats are extended.

c. Check that artificial feel remains same for lateral and longitudinal control. Rudder pedal forces lighten approximately 50%.

### DIRECTIONAL CONTROLLER CHECK.

Have ground crew oscillate wing in yaw and check rudder movement. Right wing forward should give a small indication of right rudder, and vice versa. There will be no movement of the rudder pedals.

### FUEL SYSTEM CHECK.

a. Set fuel tank emergency selector switch to AFT TK. ONLY to check operation of engine fuel feed from aft tank.

b. Accelerate engine to 80% rpm.

c. Check fuel tank pressure indicators ON.

d. Set fuel tank pressure switch to OFF. Note fuel tank pressure indicators change to read OFF. Return to ON.

e. Set fuel tank emergency selector switch to MAIN TK. ONLY and operate for 30 seconds.

f. Return fuel tank emergency selector switch to NOR.

### ENGINE CHECK.

#### AUTOMATIC FUEL CONTROL SYSTEM CHECK.

With engine fuel control switch set to AUTO, accelerate from 47% to 100% rpm on burst power control lever movement. Stall free accelerations should be made in 15 seconds or less. Observe rpm and tailpipe temperature during accelerations to 100%. (See figure 5-2 for exhaust gas temperature limitations.)

#### MANUAL FUEL CONTROL SYSTEM CHECK.

A complete check of the manual fuel control system should be made prior to each flight, after each periodic maintenance inspection, and after each replacement of an engine and/or fuel control system, as follows:

a. Return power control lever to IDLE following engine check given above and allow rpm to stabilize.

b. Shift to manual fuel control. (Note if warning light glows. A momentary engine surge should be expected.)

c. Slowly and smoothly increase rpm to maximum power (MIL), while carefully monitoring tailpipe temperature. Under sea level static conditions, with manual fuel control system functioning properly, the following rpm should be obtained:

Ambient Temperature		% RPM (Minimum)
°C	°F	
38	100	98
16	60	95
-18	0	91

Higher rpm values are satisfactory, but 101% rpm should not be exceeded.

d. Reduce rpm to IDLE.

e. Return fuel control switch to AUTO after rpm stabilizes at IDLE. Warning light should go off. (A momentary surge of rpm and tailpipe temperature may accompany the returning of the fuel control switch to AUTO.)

### ELECTRICAL SYSTEM CHECK.

#### GENERATOR CHECK.

With engine idling, generator indicator light should be out. Voltmeter reading should be 27.7 ( $\pm 0.5$ ) volts.

#### INVERTER CHECK.

Check that instrument power indicator light is out.

**RADIO CHECK.**

Check communication and navigation equipment.

**FLIGHT INSTRUMENTS.**

Check S-2 compass<sup>1</sup> or MA-1 compass<sup>2</sup> operation while taxiing. See Flight Instruments paragraph, Section I, for operation of the compasses. Erect attitude gyro.

**TAXIING.**

Taxiing is facilitated by the use of nose wheel steering. The system has nose wheel travel 40° left or right of neutral at maximum pedal deflection, making possible sharp turns such as those required when maneuvering out of or into a small parking spot. With nose wheel steering on and full pedal throw, the airplane appears to pivot about a point directly beneath the inside wing tip. It is possible to tighten the turn past the 40° nose wheel swivel by the use of differential wheel braking. The nose wheel steering system may be energized at any time while on the ground but will not engage unless nose wheel position and rudder pedal position are compatible. If the nose wheel is in the 40° left or right of neutral band, motion of the rudder pedals while the system is energized will complete the engagement. If the nose wheel is out of the 40° left or right of neutral band, differential braking is required for steering.

To energize the system, either the nose wheel steering switch (12, figure 1-7) must be actuated or the arresting hook must be extended.

**Note**

Flaps must be down for adequate nose wheel steering travel, as rudder pedal travel is restricted by rudder stops when the flaps are up.

Nose wheel steering effectively reduces the degree of physical effort required to operate the airplane while taxiing. It also reduces the average power required for taxiing from about 50-70% rpm to idle (approximately 42% rpm). The airplane's response to steering control is excellent and the pilot could become lulled into a false sense of security at taxi speeds in excess of prudent values, since these speeds could be attained at idle power. To stop, apply brakes evenly. Restrict taxi time to an absolute minimum, as fuel consumption during ground operation is exceedingly high.

**CAUTION**

Reduce airplane taxiing speed before attempting a turn. The combination of power nose wheel steering, narrow tread and soft shock struts may result in a taxi accident if the airplane is turned at a high taxi speed.

**BEFORE TAKE-OFF.****PREFLIGHT AIRCRAFT CHECK.**

- a. Control surfaces move freely.
- b. Set attitude and directional gyros as desired. Check operation.
- c. Check that both hydraulic pressure gages indicate 3000 psi.
- d. Set air conditioning system manual control to RAM AIR.

**Note**

Under certain atmospheric conditions of high temperature and humidity, chiefly at low altitudes, cockpit air conditioning system diffusers will emit fog. If the system setting is on COLD, this fog becomes thicker as the cockpit temperature falls but can be eliminated by adjusting either the manual or automatic control knob to HOT. The fog may be dense enough to resemble smoke; therefore, to avoid cause for undue alarm, until the pilot has become accustomed to the characteristics of the air conditioning system, make take-offs with the manual knob set to RAM AIR.

- e. Oxygen on 100%.
- f. Yaw damper and rudder trim switch ON.
- g. Recheck for proper trim settings.
- h. Fuel tank pressure switch ON for field take-offs; OFF for carrier take-offs.
- i. Canopy closed or as directed by local Standing Operating Procedures for field take-offs; at pilot's discretion or as directed by local Standing Operating Procedures for carrier take-offs.

**TAKE-OFF.**

- a. Complete take-off check list (figure 2-4).
- b. Hold brakes and advance power control lever.
- c. With engine at take-off rpm, release brakes and begin take-off run.
- d. Keep nose wheel on deck so that drag will be held to a minimum. With full fuel load and recommended longitudinal trim setting, control stick may be kept in neutral. At low fuel loadings (aft cg) some reduction in airplane nose-up trim may be required.
- e. Maintain direction with nose wheel steering or brakes and flaperons until rudder control becomes effective (60-70 knots IAS). A raised flaperon adds drag to assist braking on that side. Excessive use of brakes or flaperons will increase take-off distance.
- f. For minimum ground run distance: In order to attain minimum ground run distance given in figure A-5

<sup>1</sup> Airplanes BuNo. 138610a through 138645b.

<sup>2</sup> Airplanes BuNo. 141728c and subsequent.



Figure 2-4. Take-off Check List

of Appendix I, raise nose wheel at five knots below lift-off IAS given in table II-I. If minimum ground run distance is not marginal, it is advantageous to take off at a higher airspeed than minimum speeds given in table II-I in order to attain more positive control and a greater airspeed margin above stall (see Obstacle Clearance paragraph, this section). For every 1 knot increase in lift-off speed over minimum speeds in table II-I, ground run is increased 2% above minimum ground run.

**Note**

Raising the nose wheel too early increases the drag and thus lengthens the take-off run.

Sufficient lateral control is available to fly airplane safely after taking off with one wing tank full and one empty.

g. Retract landing gear when definitely airborne (retraction time approximately 10 seconds).

**Note**

The landing gear is designed to retract hydraulically up to 200 knots IAS.

- h. Close canopy, if open.
- i. Raise flaps above 180 knots IAS.
- j. Set isolation system control lever to FLIGHT.
- k. Fuel tank pressure switch ON.
- l. Accelerate to best climbing speed. See figure A-6, Appendix I.
- m. For take-off emergencies, see Section III.

**OBSTACLE CLEARANCE.**

Estimated total distances to clear an object are given in figure A-5, Appendix I. See table II-I for obstacle clearance lift-off speeds. These distances are based on a minimum ground run plus the following procedures:

a. Retract landing gear immediately upon becoming airborne.

b. After lifting-off, level out and accelerate to obstacle clearance airspeed (listed in table), then pull up smoothly and climb out over obstacle, maintaining a constant CAS until obstacle is cleared. (On a cold day when available thrust is high, care should be taken not to pull too tight a turn. Under these conditions, it may be necessary to allow airplane to accelerate slightly while pulling into climb in order to prevent stalling the airplane. Climb out is still done at a constant speed.)

c. After clearing obstacle, retract flaps above 180 knots IAS and accelerate to best climb speed (see figure A-6, Appendix I).

The total drag of the airplane rolling on the runway in the three wheel attitude is less than the drag in flight at the same airspeed. Therefore, the MINIMUM total distance to clear an obstacle is attained by keeping the airplane on the ground with the nose wheel down until the obstacle clearance speed is reached, then pulling off smoothly into a climb and maintaining a constant airspeed until obstacle is cleared. This procedure involves a ground run approximately 20% longer than minimum

**TABLE II-I**  
LIFT-OFF AIRSPEEDS

Airplane Weight (pounds)	Minimum Lift-off CAS (knots)	Obstacle Clearance CAS (knots)
22000	143	156
21000	139	152
20000	136	148
19000	123	144

run, but results in a total obstacle clearance distance 5 to 10% less than that given in figure A-5, Appendix I. At high altitude and temperature conditions, this difference may become significant.

### CLIMB.

Climb at take-off rpm for tailpipe temperature limits. See figure A-6, Appendix I for best climb speeds.

### FLIGHT CHARACTERISTICS.

See Section VI.

### SYSTEMS OPERATION.

See Section VII.

### DESCENT.

Utilize speed brakes to decelerate. Use of idle rpm (power control lever at IDLE setting) during descent will conserve fuel.

### PRE-TRAFFIC PATTERN CHECK LIST.

See figure 2-5 for landing check list.

- a. Set isolation system control lever to TAKE-OFF LANDING.
- b. Empty wing tanks.
- c. Check communication equipment.
- d. Set wing tanks dump switch to NOR.
- e. Check that fuel tank pressure switch is ON. See Weight Limitations paragraph, Section V.
- f. Extend arresting hook if required.

### TRAFFIC PATTERN CHECK LIST.

(See figure 2-6.)

- a. Lower landing gear when below 270 knots IAS.

### Note

The nose wheel may not lock down at speeds above 180 knots IAS.

If the speed brakes have been used to decelerate, they will retract automatically when the landing gear control lever is set to DOWN. Check for retraction.

- b. Lower flaps when below 270 knots IAS.
- c. Depress brake pedals to check "feel."
- d. Check fuel quantity.
- e. Check that shoulder harness and seat belt are locked and tightened.
- f. Canopy closed or as directed by local Standing Operating Procedures for field landings; at pilot's discretion or as directed by local Standing Operating Procedures for carrier landings.

### LANDING.

For field landings, make final approach at 125% of power-off stall speed with wheels and flaps extended. Avoid high rates of descent on final approach as the airplane's response to landing flare-out is slower than that of a straight wing airplane. Touch down at 115% of power-off stall speed. See table II-II for normal field landing airspeed and table II-III for power-off stall speeds.

### Note

Sufficient lateral control is available to land the airplane safely with one wing tank empty and one full. For asymmetric flap or slat contingencies, see Malfunction of Slats or Flaps paragraph in Section III.

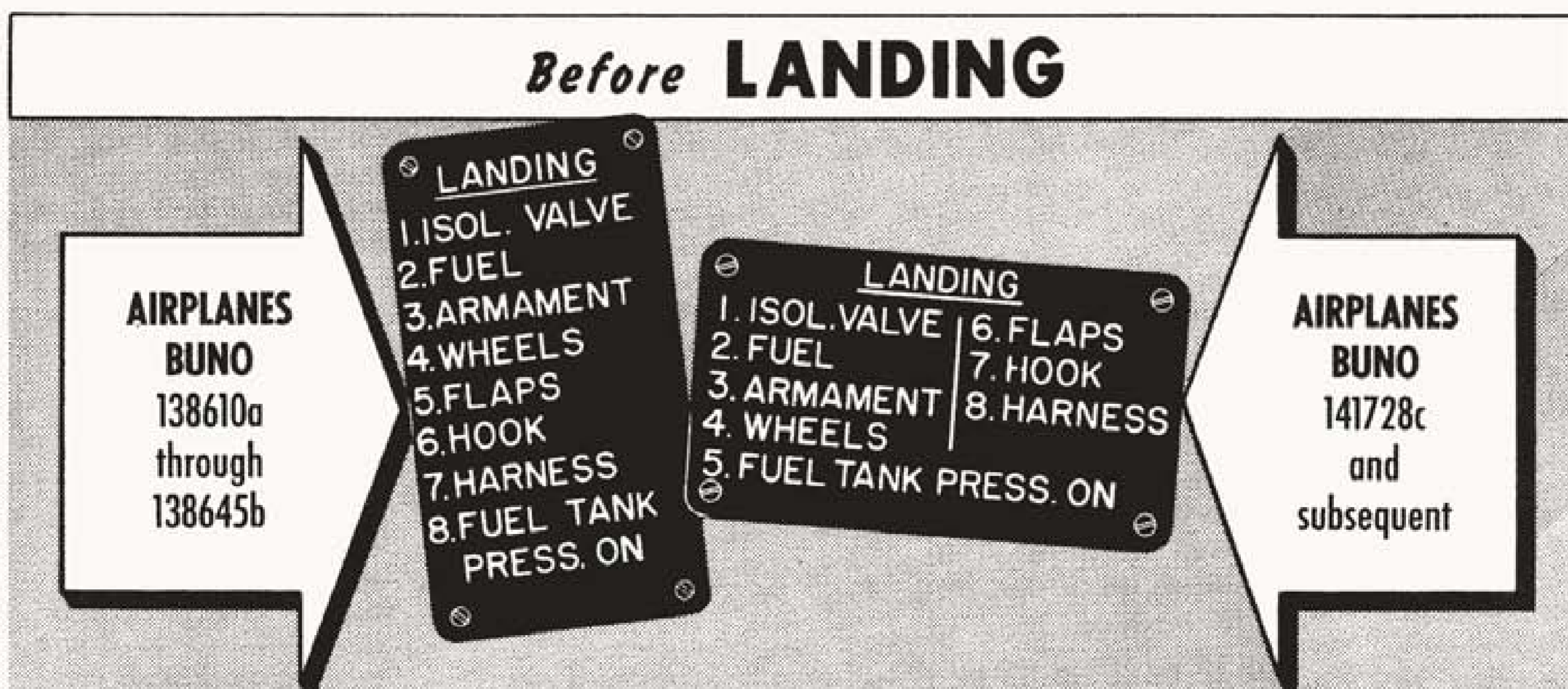

Figure 2-5. Landing Check List



# LANDING PATTERN DIAGRAM

ENTER PATTERN AT PRESCRIBED ALTITUDE AND SPEED. SET ISOLATION SYSTEM CONTROL LEVER TO TAKE-OFF/LANDING

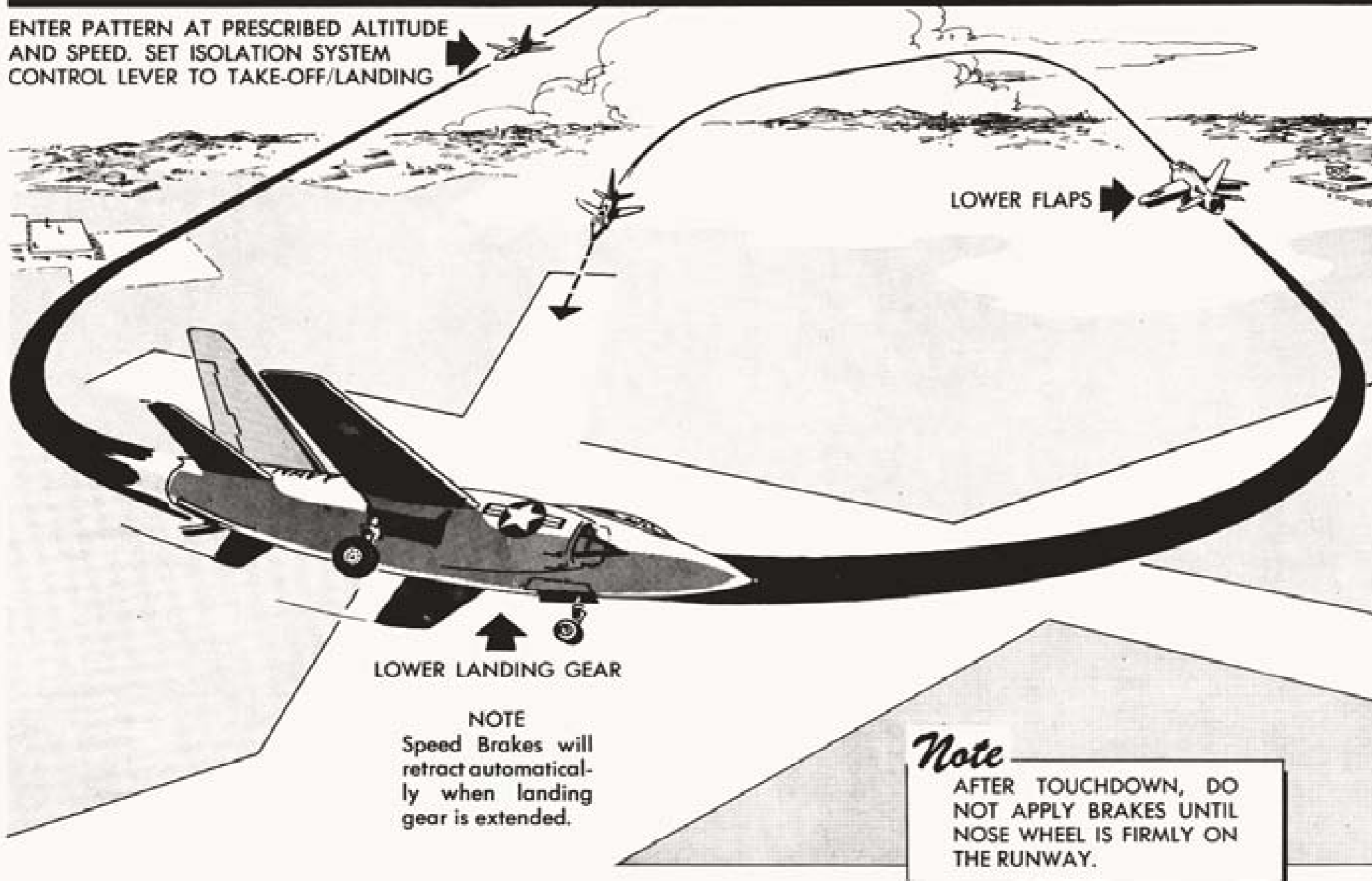

Figure 2-6. Landing Pattern Diagram

**CAUTION**

Because of the slower accelerating characteristics of the jet engine, the landing traffic pattern should be made to permit engine operation above 70% rpm.

**TABLE II-II**  
NORMAL FIELD LANDING AIRSPEEDS

<i>Airplane Weight (pounds)</i>	<i>Normal Approach CAS (knots)</i>	<i>Normal Touch-down CAS (knots)</i>
18000	147	135
16000	138	127
14000	129	119

**TABLE II-III**  
POWER-OFF STALL SPEEDS  
LOW ALTITUDE—LANDING CONFIGURATION

(Angle of Bank—0° Load Factor—1.0)	
<i>Gross Weight (pounds)</i>	<i>Airspeed (knots-CAS)</i>
13000	99
15000	107
17000	114
19000	120

Brakes should be applied after the nose wheel has contacted the runway. For extended tire life, use only as much braking as necessary.

**Note**

During initial roll-out, the flaps are reasonably effective for decelerating if the nose of the airplane is held high.

**CROSS-WIND LANDING.**

The airplane has excellent cross-wind landing characteristics. The best approach technique consists primarily of crabbing, and some slipping. The airplane should be maneuvered out of the crab just prior to touch-down and the upwind wing held slightly low. After touch-down, the nose wheel may be held off if above 100 knots and direction maintained with rudder. Lateral control should be used to hold the wings level while the nose wheel is off the ground. As soon as the nose wheel is on the runway, alternate wheel braking action will maintain direction. The narrow tread causes a fair degree of heeling but this feels much worse than it actually is. Nose wheel steering is excellent in cross winds. It permits even braking and shorter stops. It should be remembered that the rudder pedals must be aligned with the nose wheel for steering engagement. The proper technique is to depress the nose wheel steering switch grip and then move the pedals to neutral, as they probably are displaced for directional control.

**CAUTION**

The rudder pedals may be neutralized rapidly, but after nose wheel steering is engaged, exercise caution, as it is easy to overcontrol at high speed.

If arresting hook is extended, either in trail or stinger position, nose wheel steering will become active as soon as the left wheel is solidly on the ground.

With a small amount of experience, nose wheel steering may be used safely during all normal ground roll speeds.

**WAVE-OFF.**

Remember that the jet engine will not respond as quickly as a reciprocating engine. Maintain at least 70% rpm while in the landing pattern to assist in making a rapid wave-off.

- Set power control lever full forward; because of excessive fuel consumption, use afterburner only if necessary.
- Retract landing gear when climbing.
- Raise flaps above 180 knots IAS.

**AFTER LANDING.**

- Leave flaps down for maximum nose wheel steering effectiveness.
- If tailpipe temperature is high from hard taxiing or stationary ground running, operate at 55-65% rpm for one minute.

**SHIPBOARD OPERATING PROCEDURE.****CATAPULT TAKE-OFF.****SPOTTING.**

Catapult spotting can be effected by taxiing onto the catapult from astern utilizing nose wheel steering or by approaching the catapult from a shallow angle with steering being done externally with a nose wheel steering bar. If the airplane is taxied onto the catapult from astern, one of the dual nose wheels must run directly over the shuttle to avoid damage to the wheel rims. This requirement necessitates careful response to taxi director signals. If a nose wheel steering bar is used for spotting, the pilot must avoid engaging the nose gear steering system in order to permit turning of the wheels and to avoid injury to personnel or damage to the steering bar if the rudder pedals are moved.

**CAUTION**

The nose gear steering system cannot be disengaged if the arresting hook is in the stinger position as may occur during qualification

periods when the airplane is spotted on the catapult immediately after landing. The arresting hook must be stowed before a nose wheel guide bar can be safely and effectively used.

**TRIM.**

See table II-IV for trim settings for catapult take-off. Longitudinal trim settings within the bands in table II-IV are not critical and may be adjusted to the desires of individual pilots as familiarity is gained with flyaway characteristics. The settings are applicable for gross weights from 17500 pounds to the maximum weight attainable with permissible store loadings.

**TABLE II-IV**

<i>Predicted End Airspeed</i>	<i>Longitudinal Trim Marks Nose-up</i>	<i>Lateral and Directional Trim</i>
5 to 30 knots above minimum	7 to 5-1/2	0
0 to 5 knots above minimum	8 to 7	0

**LAUNCH CHARACTERISTICS.**

Catapult tracking characteristics for off-center launches are excellent with no tendency toward directional oscillations during the catapult power stroke. It is recommended that the hook be stowed rather than left in the stinger position to avoid possible fouling of the hook by bridle arrester components and to insure disengagement of nose gear steering during the power stroke. Nose-up rotation is necessary following the launch because the attitude of the airplane on deck will not permit level flight at launching speeds. The recommended trim settings provide the necessary rotation. On launches at or near minimum end airspeeds, marked settling may be expected to occur during the period that the airplane is rotating to the level flight attitude and acceleration after launch will be slow. Under this condition too rapid rotation may result in heavy buffeting and can further reduce the acceleration rate. At heavy gross weights and high atmospheric temperatures, minimum catapulting end airspeeds are governed primarily by the amount of excess thrust available. Minimum catapult end airspeeds and limiting temperatures are available in the applicable aircraft launching bulletin.

**LAUNCH PROCEDURE.**

Steps in pilot procedure for catapult take-off are as follows:

- a. Complete the take-off check list. Set longitudinal trim setting for the predicted end airspeed.
- b. When the airplane is tensioned on the catapult and upon signal from the catapult officer, advance the power control lever to MIL or AFTERBURNER and grasp the catapult handgrip.
- c. Check all instruments and lights for proper indication.

d. Place head firmly against headrest and feet against lower portion of rudder pedals.

e. Signal the catapult officer when ready for launching. During the power stroke, the stick should be left in the trim position. The hand may be left clear of the stick until launch forces permit smooth application of controls. Forward stick pressure followed by retrimming will be required as the airplane accelerates after attaining flight attitude. A clearing turn should not be started until well past the bow.

To avoid excess fuel consumption, afterburner launches should not be made unless required by overriding operational considerations.

**CARRIER LANDING (MIRROR).**

**PATTERN.**

The carrier landing maneuver begins at 500 feet on the down-wind leg parallel to the ship's course. All landing check list items should be completed prior to reaching the abeam position so that full attention can be devoted to angle of attack, altitude and line-up. The down-wind leg should be wide enough abeam to permit an approach turn using a bank of 15 to 20 degrees. The approach turn is started 3 to 5 seconds after passing abeam the stern of the ship. At this point, a speed of approximately 10 knots greater than the final approach speed will eliminate the necessity for adding power during a level approach turn. The turn should be planned to facilitate intercepting the mirror glide path in a wings level attitude at the recommended approach angle of attack.

**APPROACH AIRSPEED (ATTITUDE).**

The recommended indicated angle of attack for carrier approaches is 20 units. This angle of attack will provide mirror approach speeds in the range indicated in figure 2-7. In level (LSO) approaches, indicated airspeeds will be 3 to 5 knots lower than in descending approaches for a given indicated angle of attack.

**FINAL APPROACH.**

Simultaneous roll-out from the approach turn and start of a descent require an rpm reduction of approximately 8%. In connection with power control, the position of approach speeds on the back side of the power required curve requires special consideration. A pilot unfamiliar with operation in this region may find himself "hunting" for the proper power setting as his carrier approach develops. To slow from one stabilized speed to a new lower speed, the power must first be reduced in order to decelerate without climbing, and then increased beyond the original setting to maintain the new lower speed. Following the normal tendency to use a lower power setting to hold a new lower airspeed will result in settling late in the approach and if carried too far, can result in settling to a degree where the thrust available for correction is marginal. Operation in the reverse slope of the drag curve results in increases in airplane drag with increases in nose attitude which are

## MIRROR APPROACH SPEED RANGE

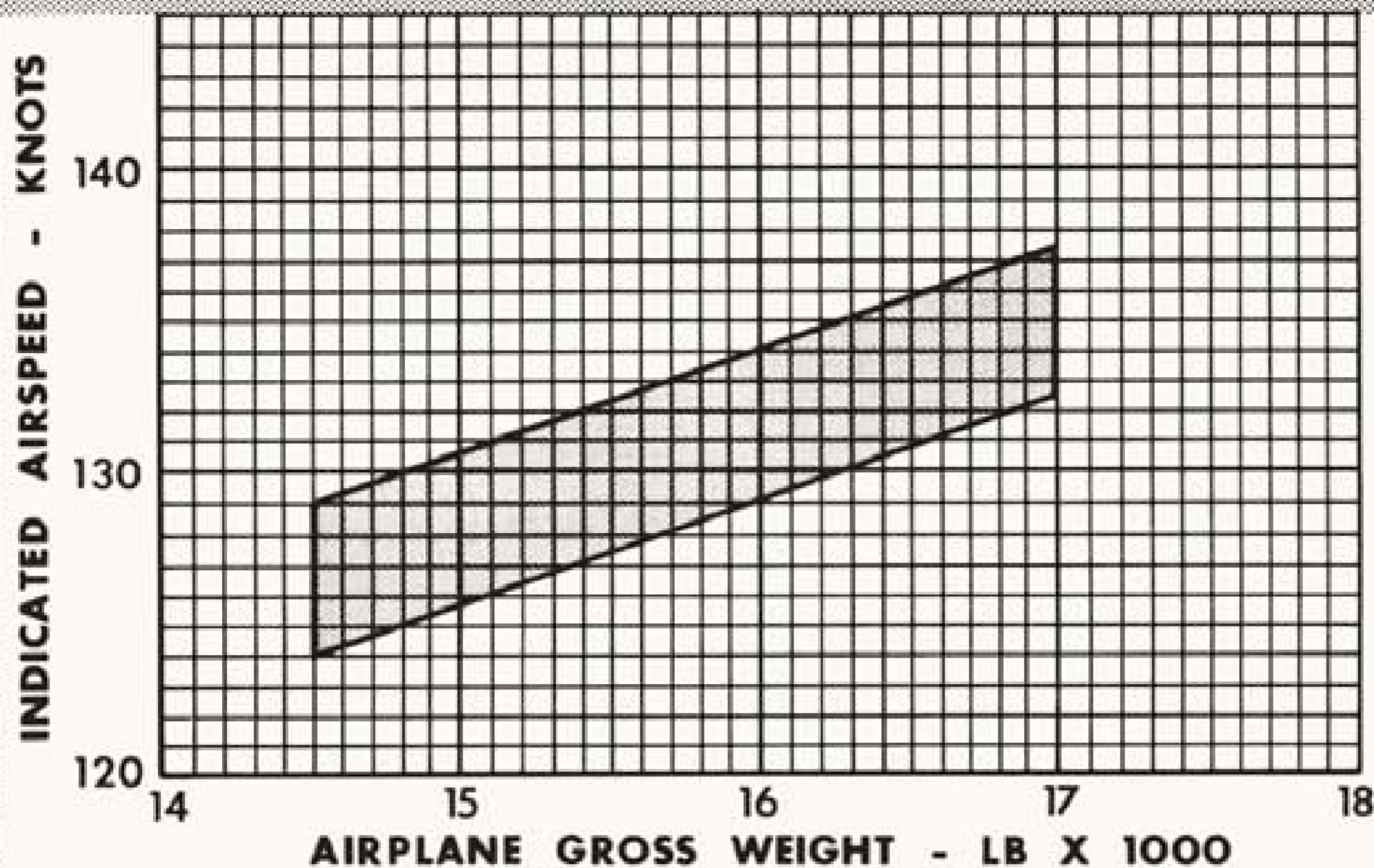

Figure 2-7. Mirror Approach Speed Range

unusually high in relation to the associated increase in lift. This characteristic requires judicious use of power for control of the flight path as well as for air-speed control in mirror approaches.

Actuation of spoilers in the area of turbulence aft of the island can induce settling which will be critical if the approach angle of attack is higher than that recommended.

Early familiarity should be gained with the use of the cockpit angle of attack indexer in landing approaches. Within the permissible range of landing weights, the angle of attack indexer provides the proper approach speed regardless of gross weight variation when the indexer is preset for the recommended approach angle of attack. The position of the indexer on the forward windshield frame relieves the pilot of frequent checks of panel instruments and permits greater concentration on line-up and the mirror. Approaches can be made using the indexer alone for cockpit reference. The indexer is especially helpful at night as light indications are apparent in the pilot's peripheral vision while keeping the deck and mirror under constant observation.

### CAUTION

Carrier landings on angled deck ships should be made with particular attention to achieving a good line-up and avoiding landings with right to left drift which, when associated

with the increased run-out of angled deck arresting gears, can result in the airplane coming to rest in the port catwalk.

Burble effect, present under all wind conditions, produces a definite tendency for the right wing to drop as the airplane approaches and passes the round-down at the forward end of the landing area on angled deck ships.

### LANDING TECHNIQUE.

Landings following mirror approaches should be made by maintaining the approach attitude and mirror glide path to the deck. No attempt should be made to flare landings. Nose-up rotation will not measurably affect the sinking speed but can result in initial contact being made by the skag which can drag arresting wires from the yielding elements and reduce the probability of engagement. Excessively tail-low landings will also result in loads on the nose gear which exceed structural limits. Power should not be reduced prior to completion of the landing run-out on angled deck ships. The importance of holding the mirror glide path to the deck is emphasized. Seemingly minor deviations from the glide path can result in high sink speeds and resulting destructive landing gear loads.

Directional stability during arrested landing run-out is good with satisfactory resistance to rolling and yawing effect of off-center landings. The nose gear steering device has a definite steadying effect on run-out characteristics.

**BOLTER.**

If an arresting wire is not engaged, apply Military thrust and rotate airplane to the take-off attitude. Do not commence a turn until a definite rate of climb has been established.

**WAVE-OFF.**

In event of wave-off, apply Military thrust and level wings as soon as possible. Wave-off characteristics are satisfactory in the wings level condition and maneuvering should be kept to a minimum until air-speed has been increased. If afterburner thrust is selected for wave-off, a delay in afterburner ignition of at least 1.5 seconds must be expected.

**DECK HANDLING.**

Automatic engagement of the nose wheel steering system while the arresting hook is down or in the stinger position facilitates ease of handling while clearing the landing area. The nose wheel steering sector ( $\pm 40^\circ$ ) is not of sufficient magnitude to permit maneuvering on and off side elevators without swivelling the nose gear beyond the steering sector limits. High power settings and heavy brake pedal forces are required for steering when the nose wheels are canted beyond the steering sector limits and their use should be anticipated by the pilot.

**CARRIER LANDING (LSO).**

The carrier landing pattern used for an LSO approach varies from the mirror pattern in that the approach turn is started when abeam the LSO at an altitude of approximately 200 feet. In answer to the cut signal, lower the nose to establish a definite rate of descent. Maintain this descent attitude to the deck, making no attempt to flare.

**STOPPING ENGINE.**

a. Retard power control lever to OFF from a stabilized rpm. Immediately set d-c power switch to OFF to conserve battery while engine is running down.

**Note**

Check that the engine runs down freely. Engine driven accessories will slow down the engine. Any undue friction should be noticeable.

b. After engine stops rotating, set d-c power switch to BAT. & GEN. and set fuel master switch to OFF.

c. After 10 seconds, set engine master and d-c power switches to OFF.

**BEFORE LEAVING AIRPLANE.**

a. Set all switches off.

b. Close canopy, using handle on left side of fuselage, after leaving the cockpit.

c. Be sure airplane is properly chocked.

**This page intentionally left blank.**